

Power Flow Control by Using DPFC

T. Obulesu¹, S. Sarada², M. Sudheer babu³

^{1,3}M.Tech Student, Department of EEE A.I.T.S Engineering College Kadapa, India

²Associative professor of AITS college

Abstract: this paper presents a new component within the flexible ac-transmission system (FACTS) family, called distributed power-flow controller (DPFC). The DPFC is derived from the unified power-flow controller (UPFC). The DPFC can be considered as a UPFC with an eliminated common dc link. The active power exchange between the shunt and series converters, which is through the common dc link in the UPFC, is now through the transmission lines at the third-harmonic frequency. The DPFC employs the distributed FACTS (D-FACTS) concept, which is to use multiple small-size single-phase converters instead of the one large-size three-phase series converter in the UPFC. The large number of series converters provides redundancy, thereby increasing the system reliability. As the D-FACTS converters are single-phase and floating with respect to the ground, there is no high-voltage isolation required between the phases. Accordingly, the cost of the DPFC system is lower than the UPFC. The DPFC has the same control capability as the UPFC, which comprises the adjustment of the line impedance, the transmission angle, and the bus voltage. The principle and analysis of the DPFC are presented in this paper and the corresponding experimental results that are carried out on a scaled prototype are also shown.

Index Terms: AC–DC power conversion, load flow control, power electronics, power semiconductor devices, power system control, power-transmission control.

I. INTRODUCTION

THE GROWING demand and the aging of networks make it desirable to control the power flow in power-transmission systems fast and reliably. The flexible ac-transmission system (FACTS) that is defined by IEEE as “a power-electronic-based system and other static equipment that provide control of one or more ac-transmission system parameters to enhance controllability and increase power-transfer capability” [2], and can be utilized for power-flow control. Currently, the unified power-flow controller (UPFC) shown in Fig. 1, is the most powerful FACTS device, which can simultaneously control all the parameters of the system: the line impedance, the transmission angle, and bus voltage.

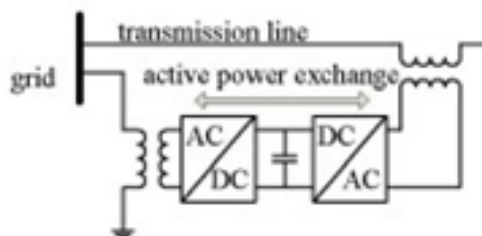

Fig. 1. Simplified representation of a UPFC.

The UPFC is the combination of a static synchronous compensator (STATCOM) and a static synchronous series compensator (SSSC), which are coupled via a common dc link, to allow bidirectional flow of active power between the series output terminals of the SSSC and the shunt output terminals of the STATCOM. The converter in series with the line provides the main function of the UPFC by injecting a four-quadrant voltage with controllable magnitude and phase. The injected voltage essentially acts as a synchronous ac-voltage source, which is used to vary the transmission angle and line impedance, thereby independently controlling the active and reactive power flow through the line. The series voltage results in active and reactive power injection or absorption between the series converter and the transmission line. This reactive power is generated internally by the series converter (see e.g., SSSC), and the active power is supplied by the shunt converter that is back-to-back connected. The shunt converter controls the voltage of the dc capacitor by absorbing or generating active power from the bus; therefore, it acts as a synchronous source in parallel with the system. Similar to the STATCOM, the shunt converter can also provide reactive compensation for the bus.

The components of the UPFC handle the voltages and currents with high rating; therefore, the total cost of the system is high. Due to the common dc-link interconnection, a failure that happens at one converter will influence the whole system. To achieve the required reliability for power systems, bypass circuits and redundant backups (backup transformer, etc.) are needed, which on other hand, increase the cost. Accordingly, the UPFC has not been commercially used, even though, it has the most advanced control capabilities.

This paper introduces a new concept, called distributed power-flow controller (DPFC) that is derived from the UPFC. The same as the UPFC, the DPFC is able to control all system parameters. The DPFC eliminates the common dc link between the shunt and series converters. The active power exchange between the shunt and the series converter is through the transmission line at the third-harmonic frequency. The series converter of the DPFC employs the distributed FACTS

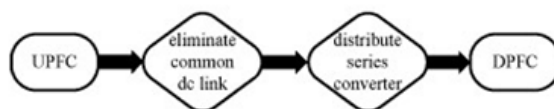
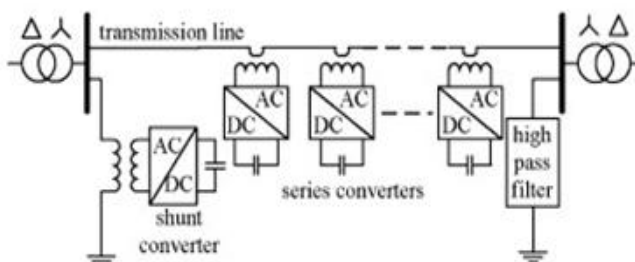

Fig. 2. Flowchart from UPFC



to DPFC.

Fig. 3. DPFC configuration.

(D-FACTS) concept . Comparing with the UPFC, the DPFC have two major advantages: 1) low cost because of the low voltage isolation and the low component rating of the series converter and 2) high reliability because of the redundancy of the series converters. This paper begins with presenting the principle of the DPFC, followed by its steady-state analysis. After a short introduction of the DPFC control, the paper ends with the experimental results of the DPFC.

II. DPFC PRINCIPLE

Two approaches are applied to the UPFC to increase the reliability and to reduce the cost; they are as follows. First, eliminating the common dc link of the UPFC and second distributing the series converter, as shown in Fig. 2. By combining these two approaches, the new FACTS device—DPFC is achieved.

The DPFC consists of one shunt and several series-connected converters. The shunt converter is similar as a STATCOM, while the series converter employs the D-FACTS concept, which is to use multiple single-phase converters instead of one large rated converter. Each converter within the DPFC is independent and has its own dc capacitor to provide the required dc voltage. The configuration of the DPFC is shown in Fig. 3.

As shown, besides the key components, namely the shunt and series converters, the DPFC also requires a high-pass filter that is shunt connected at the other side of the transmission line, and two Y-Δ transformers at each side of the line. The reason for these extra components will be explained later.

The unique control capability of the UPFC is given by the back-to-back connection between the shunt and series converters, which allows the active power to exchange freely. To ensure that the DPFC have the same control capability as the UPFC, a method that allows the exchange of active power between converters with eliminated dc link is the prerequisite.

A. Eliminate DC Link

Within the DPFC, there is a common connection between the ac terminals of the shunt and the series converters, which is the transmission line. Therefore, it is possible to exchange the active power through the ac terminals of the converters. The method is based on the power theory of nonsinusoidal components. According to the Fourier analysis, a nonsinusoidal voltage and current can be expressed by the sum of sinusoidal functions in different frequencies with different amplitudes. The active power resulting from this nonsinusoidal voltage and current is defined as the mean value of the product of voltage and current.

cross product of terms with

Since the integrals of all the different

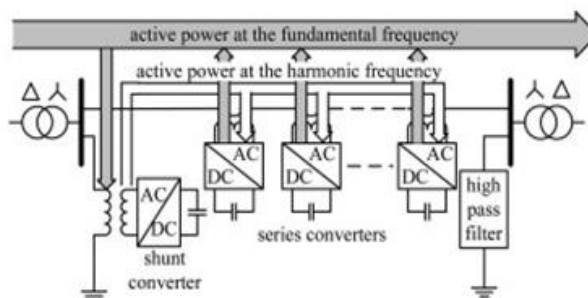

Fig. 4. Active power exchange between DPFC converters.

Frequencies are zero; the active power can be expressed by

$$P = \sum_{i=1}^{\infty} V_i I_i \cos \phi_i \quad (1)$$

Where V_i and I_i are the voltage and current at the i th harmonic frequency, respectively, and ϕ_i is the corresponding angle between the voltage and current. Equation (1) describes that the active power at different frequencies is isolated from each other and the voltage or current in one frequency has no influence on the active power at other frequencies. The independency of the active power at different frequencies gives the possibility that a converter without power source can generate active power at one frequency and absorb this power from other frequencies.

By applying this method to the DPFC, the shunt converter can absorb active power from the grid at the fundamental frequency and inject the current back into the grid at a harmonic frequency. This harmonic current will flow through the transmission line. According to the amount of required active power at the fundamental frequency, the DPFC series converters generate a voltage at the harmonic frequency, thereby absorbing the active power from harmonic components. Assuming a lossless converter, the active power generated at fundamental frequency is equal to the power absorbed from the harmonic frequency. For a better understanding, Fig. 4 indicates how the active power exchanges between the shunt and the series converters in the DPFC system.

The high-pass filter within the DPFC blocks the fundamental frequency components and allows the harmonic components to pass, thereby providing a return path for the harmonic components. The shunt and series converters, the high-pass filter, and the ground form the closed loop for the harmonic current.

Due to the unique characters of third-harmonic frequency components, the third harmonic is selected to exchange the active power in the DPFC. In a three-phase system, the third harmonic in each phase is identical, which is referred to as "zero-sequence." The zero-sequence harmonic can be naturally blocked by Y-Δ transformers, which are widely used in power system to change voltage level. Therefore, there is no extra filter required to prevent the harmonic leakage to the rest of the network. In addition, by using the third harmonic, the costly high-pass filter, as shown in Fig. 4, can be replaced by a cable that is connected between transformer on the right side in Δ winding appears open circuit to harmonic current will flow through the grounding cable, as shown in high-pass filter is eliminated.

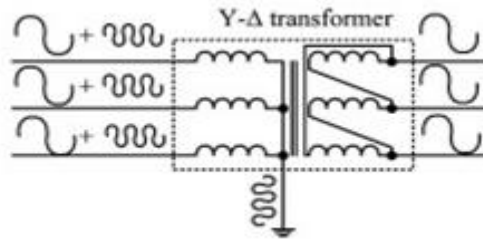

the neutral point of the Y-Δ Fig. 3 and the ground. Because the third-harmonic current, all the Y-winding and concentrate to Fig. 5. Therefore, the large-size

Fig. 5. Utilize grounded Y-Δ for the zero-sequence third harmonic.

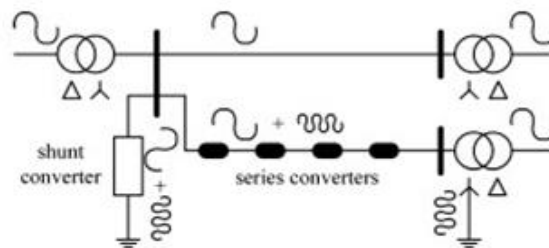

transformer to provide the path

Fig. 6. Route the harmonic current by using the grounding status of the Y-Δ transformer.

Another advantage of using third harmonic to exchange activepower is that the way of grounding of Y-Δ transformers can be used to route the harmonic current in a meshed network. If the branch requires the harmonic current to flow through, the neutral point of the Y-Δ transformer at the other side in that branch will be grounded and vice versa. Fig. 6 demonstrates a simple example of routing the harmonic current by using a grounding Y-Δ transformer. Because the transformer of the line without the series converter is floating, it is open circuit for third-harmonic components. Therefore, no third-harmonic current will flow through this line.

Theoretically, the third-, sixth-, and ninth-harmonic frequencies are all zero-sequence, and all can be used to exchange active power in the DPFC. As it is well known, the capacity of a transmission line to deliver power depends on its

impedance. Since the transmission-line impedance is inductive and proportional to the frequency, high-transmission frequencies will cause high impedance. Consequently, the zero-sequence harmonic with the lowest frequency—third harmonic is selected.

B. Distributed Series Converter

The D-FACTS is a solution for the series-connected FACTS, which can dramatically reduce the total cost and increase the reliability of the series FACTS device. The idea of the D-FACTS is to use a large number of controllers with low rating instead of one large rated controller. The small controller is a single-phase converter attached to transmission lines by a single-turn transformer. The converters are hanging on the line so that no costly high-voltage isolation is required. The single-turn transformer uses the secondary winding, inserting the line directly. Each D-FACTS the line and controlled remotely communication (see Fig. 7).

The structure of the D-FACTS unit is shown in Fig. 7. The D-FACTS unit is a single-phase device floating on lines, between phases are avoided. The any transmission-voltage level, supporting phase-ground voltage rating of each unit is units are clamped on transmission

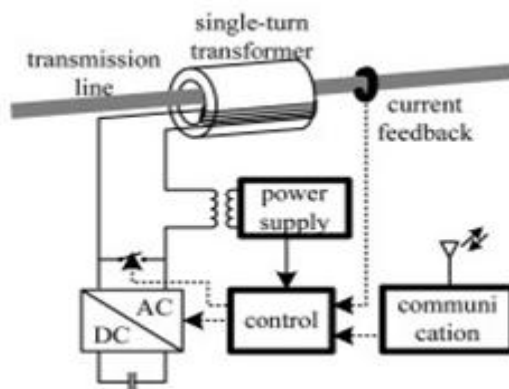

transmission line as the controllable impedance into module is self-powered from by wireless or power-line

FACTS results in low cost FACTS units are single-high-voltage isolations unit can easily be applied at be- cause it does not require isolation. The power and relatively small. Further, the lines, and therefore, no

Fig. 7. D-FACTS unit configuration [7].

land is required. The redundancy of the D-FACTS provides an uninterrupted operation during a single module failure, thereby giving a much higher reliability than other FACTS devices.

C. DPFC Advantages

The DPFC can be considered as a UPFC that employs the D FACTS concept and the concept of exchanging power through harmonic. Therefore, the DPFC inherits all the advantages of the UPFC and the D-FACTS, which are as follows.

- 1) High control capability. The DPFC can simultaneously control all the parameters of the power system: the line impedance, the transmission angle, and the bus voltage. The elimination of the common dc link enables separated installation of the DPFC converters. The shunt and series converters can be placed at the most effectively location. Due to the high control capability, the DPFC can also be used to improve the power quality and system stability, such as low-frequency power oscillation damping, voltage sag restoration, or balancing asymmetry.
- 2) High reliability. The redundancy of the series converter gives an improved reliability. In addition, the shunt and series converters are independent and the failure at one place will not influence the other converters. When a failure occurs in the series converter, the converter will be short-circuited by bypass protection, thereby having little influence to the network. In the case of the shunt converter failure, the shunt converter will trip and the series converter will stop providing active compensation and will act as the D-FACTS controller.
- 3) Low cost. There is no phase-to-phase voltage isolation required by the series converter. Also, the power rating of each converter is small and can be easily produced in series production lines.

However, as the DPFC injects extra current at the third-harmonic frequency into the transmission line, additional losses in the transmission line and transformer should be aware of.

III. ANALYSIS OF THE DPFC

In this section, the steady-state behavior of the DPFC is analyzed, and the control capability of the DPFC is expressed in the parameters of the network and the DPFC.

To simplify the by controllable voltage Since each converter generates frequencies, it is represented controllable voltage sources, and the other at the third-that the converters and the total active power generated sources will be zero. The simplified as one large is equal to the sum of the shown in Fig. 8.

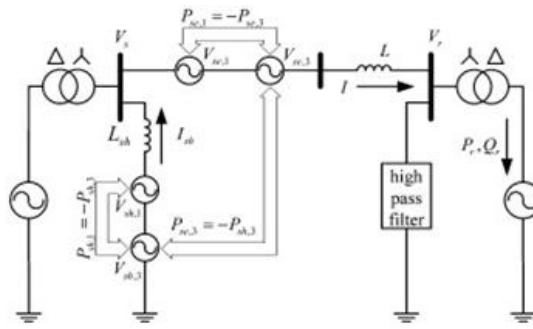

DPFC, the converters are replaced sources in series with impedance. the voltage at two different by two series-connected one at the fundamental frequency harmonic frequency. Assuming transmission line are lossless, the by the two frequency voltage multiple series converters are converter with the voltage, which voltages for all series converter, as

In Fig. 8, the DPFC is placed in a two-bus system with the sending-end and the receiving-end voltages Vs and Vr , The

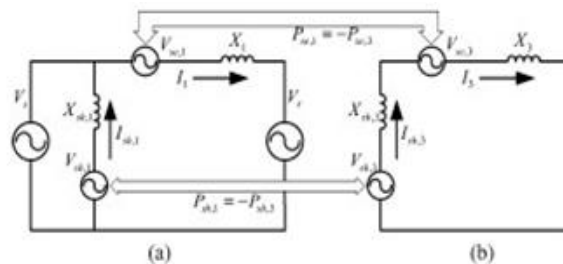
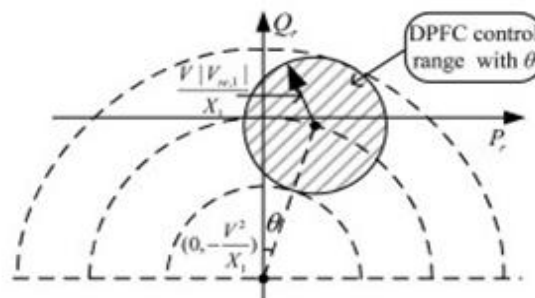

Fig. 8. DPFC simplified

transmission line is the line current I. The series converters is Vse,1 the third-harmonic converter is connected to the sending bus through the inductor Lsh and generates the voltage Vsh,1 and Vsh,3 ; the current is Ish . The active and reactive power flow at the receiving

This representation consists harmonic frequency superposition theorem, the simplified by being split into frequencies. The two circuits the link between these circuits converter, as shown in Fig. 9.



representation.

represented by an inductance L with voltage injected by all the DPFC and Vse,3 at the fundamental and frequency, respectively. The shunt converter is connected to the sending bus through the inductor Lsh and generates the voltage Vsh,1 and Vsh,3 ; the current is Ish . The active and reactive end is Pr and Or, respectively.

of both the fundamental and third-components. Based on the circuit in Fig. 8 can be further two circuits at different are isolated from each other, and is the active power balance of each

Fig. 9. DPFC equivalent circuit. (a) Fundamental frequency. (b) Third-harmonic frequency.

Fig. 10. DPFC active and reactive power control range with the transmission angle θ .

The power-flow control is represented by the active power at the receiving end. The fundamental frequency active and reactive power

where P_{r0} , Q_{r0} , and θ are the transmission angle. $X_{se,1} = \omega L_{se}$ is the line impedance at fundamental frequency, and $|V|$ is the voltage magnitude at both ends. In the P-Q-plane, the locus of compensation $f(P_{r0}, Q_{r0})$ is a circle with the radius of $|V|^2 / |X_1|$ around the center defined by coordinates $P = 0$ and $Q = -\frac{V^2}{X_1}$. Each point of this circle gives the P_{r0} and Q_{r0} values of the uncompensated system at the corresponding boundary of the attainable power flow without the DPFC. Fig. 10 shows the control range of the angle θ .

To ensure the series rotatable voltage, an active and fundamental frequency is provided by the series converter supplied by the shunt converter. This active power requirement

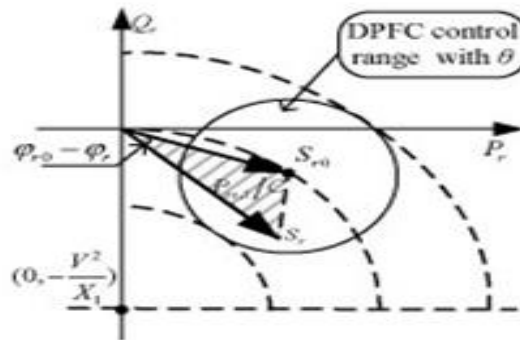
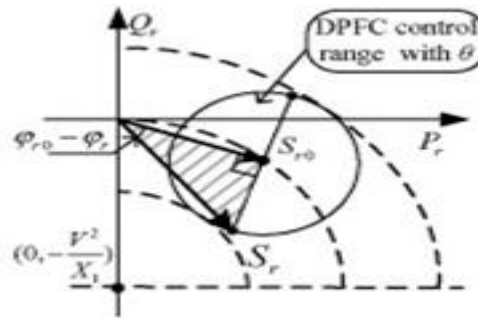

capability of the DPFC can be illustrated. The active power P_r and reactive power Q_r received at the receiving end. Because the DPFC circuit at the receiving end behaves the same as the UPFC, the power flow can be expressed as follows:

where P_r and Q_r are the active, reactive power flow, $X_{se,1}$ is the line impedance at fundamental frequency, and $|V|$ is the voltage magnitude at both ends. In the power flow without the DPFC, the locus of the uncompensated system at the corresponding boundary of the attainable power flow is a circle. Fig. 10 shows the control range of the angle θ .

This active power requirement is given by

where ϕ_{r0} is the power angle at the receiving end of the un-compensated system, which equals $\tan^{-1}(Q_{r0}/P_{r0})$ and ϕ_r is the power angle at receiving end with the DPFC compensation. The line impedance X_1 and the voltage magnitude $|V_r|$ are constant; therefore, the required active power is proportional to $|S_r - S_{r0}| \sin(\phi_{r0} - \phi_r)$, which is two times the area of the triangle that is formed by the two vectors S_{r0} and S_r . Fig. 11 illustrates the relationship between $P_{se,1}$ and the power flow at the receiving end at a certain power angle θ .

$$(P_r - P_{r0})^2 + (Q_r - Q_{r0})^2 = \frac{|V_{se,1}|^2}{X_1^2} \quad (2)$$

$$P_{se,1} = \text{Re}(V_{se,1} I_r) = \frac{X_1}{|V_r|^2} |S_r - S_{r0}| \sin(\phi_{r0} - \phi_r) \quad (3)$$

$$P_{se,1} = CA(\phi_{r0}, \phi_r) \quad (4)$$

Fig. 11. Relationship between $P_{se,1}$ and the power flow at the receiving end.

Fig. 12. Maximum active converters.

Consequently, the required converter can be written as

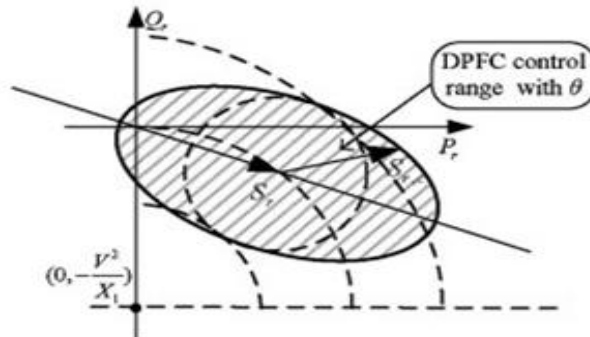

power requirement of the series active power by the series follows:

where the coefficient $C = 2X_1 / |V_r|^2$ and $A(0, r_0, r)$ is the area of the triangle $(0, S_{r0}, S_r)$. The angle difference $\phi_0 - \phi_r$ can be positive or negative, and the sign gives the direction of the active power through the DPFC series converters. The positive sign means that the DPFC series converters generate active power at the fundamental frequency and vice versa. The active power requirement varies with the controlled power flow, and the active power requirement has its maximum when the vector $S_r - S_{r0}$ is perpendicular to the vector S_{r0} , as shown in Fig. 12.

According to Fig. 12, the relationship between the powerflow control range and the maximum active power requirement can be represented by

where $|S_{r,c}|$ is the control range of the DPFC.

Each converter in the DPFC generates two frequency voltages at the same time. Accordingly, the voltage rating of the each converter should be the sum of the maximum voltage of the two frequencies component

$$P_{se,1,max} = \frac{|X_1 S_{r0}|}{|V_r|^2} |S_{r,c}| \quad (5)$$

$$V_{se,max} = |V_{se,1,max}| + |V_{se,3,max}| \quad (6)$$

$$|S_{r,c}| = \frac{|V_r V_{se,1,max}|}{X_1} \quad (7)$$

Fig. 13. DPFC power-flow

control range.

During the operation, of the se-ries converter varies fundamental frequency. When series voltage at the third-smaller than $|V_{se,3,max}|$. This potential voltage that is between $V_{se,3}$ and $|V_{se,3,max}|$ can be used to control the power flow at the fundamental frequency, thereby increasing the power-flow control region of the DPFC. When $S_{r,c}$ is perpendicular to

$$|S_{r,c}| = \frac{|V_r| (|V_{se,1,max}| + |V_{se,3,max}|)}{X_1} \quad (8)$$

the active power requirement with the voltage injected at the the requirement is low, the harmonic frequency will be

the uncompensated power S_r 0 maximum active power, and region is given by

If $S_{r,c}$ is in the same converters only provide the boundary of the DPFC control

It shows that the control extended to a shape that is in Fig. 13.

To obtain the same the rating of the DPFC frequency should be the same

Because the voltages and currents at the third-harmonic frequency have to be added, the rating of the DPFC converter is slightly larger than the UPFC. The increased rating is related with the active power exchanged at the third-harmonic frequency. For a transmission line, the line impedance $|X_1|$ is normally around 0.05 p.u. (per unit). Assuming the bus voltages $|V|$ and uncompensated power flow $|S_r|$ is 1 p.u., and then, from (7), we can see that to control 1-p.u. power flow, the exchanged active power is around 0.05 p.u.

Even with this extra voltage and current at the third-harmonic frequency, the cost of the DPFC is still much lower than the UPFC, for the following reasons: 1) the UPFC converter handles the line-to-line voltage isolation that is much larger than voltage injected by the series converter; 2) no land requirement for the series converter; and 3) the active and passive components for the DPFC converter are low-voltage components (less than 1 kV and 60 A), which is much cheaper than the high-voltage components in the UPFC.

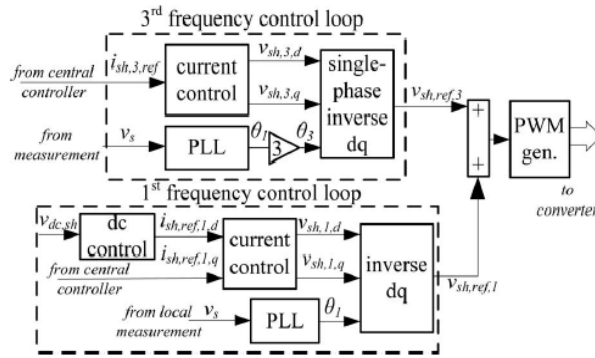

,the series converters require the radius of the DPFC control

line as $S_r = 0$, the series reactive compensation and the region will extend to region of the DPFC can be similar as an ellipse, as shown

control capability as the UPFC, converter at the fundamental as the one for the UPFC.

Fig. 14. DPFC control block diagram.

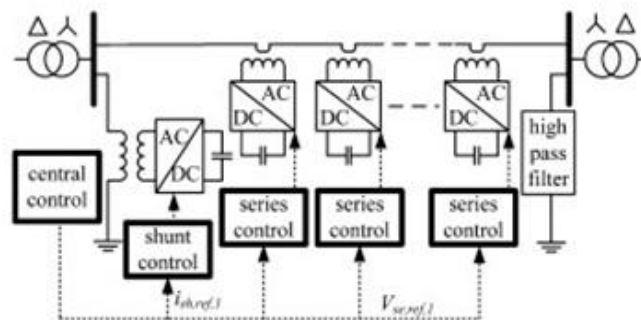

Fig. 15. Block diagram of

IV. DPFC CONTROL

To control the multiple three types of controllers; shunt control, and series

The shunt and

controllers and are responsible for maintaining their own converters' parameters. The central control takes account of the DPFC functions at the power system level. The function of each controller is listed next.

A. Central Control

The central control generates the reference signals for both the shunt and series converters of the DPFC. It is focused on the DPFC tasks at the power-system level, such as power-flow control, low-frequency power oscillation damping,

the series converter control.

converters, DPFC consists of they are central controller, control, as shown in Fig. 14. series control are local

and balancing of asymmetrical components. According to the system requirement, the central control gives corresponding voltage reference signals for the series converters and reactive current signal for the shunt converter. All the reference signals generated by the central control are at the fundamental frequency.

B. Series Control

Each series converter has its own series control. The controller is used to maintain the capacitor dc voltage of its own converter by using the third-harmonic frequency components and to generate series voltage at the fundamental frequency that is prescribed by the central control.

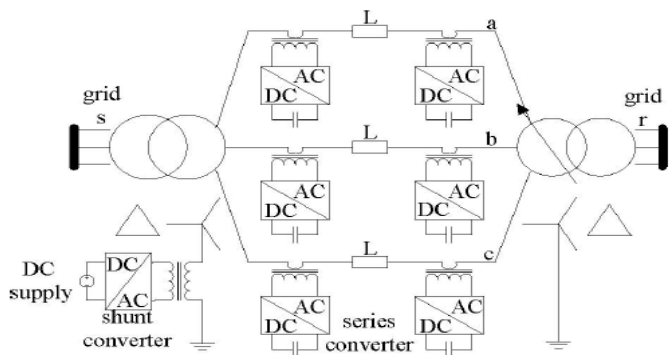
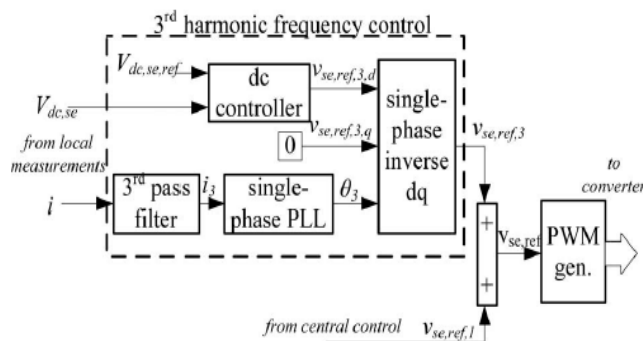

Fig. 16. Block diagram

of the shunt converter control.

The third-harmonic frequency control is the major control loop with the DPFC series converter control. The principle of the vector control is used here for the dc-voltage control. The third-harmonic current through the line is selected as the rotation reference frame for the single-phase park transformation. Because it is easy to be captured by the phase-locked loop (PLL) in the series converter. As the line current contains two frequency components, a third high-pass filter is needed to reduce the fundamental current. The d-component of the third-harmonic voltage is the parameter that is used to control the dc voltage, and its reference signal is generated by the dc-voltage control loop. To minimize the reactive power that is caused by the third harmonic, the series converter is controlled as a resistance at the third-harmonic frequency. The q-component of the third harmonic voltage is kept zero during the operation.

As the series converter is single phase, there will be voltage ripple at the dc side of each converter. The frequency of the ripple depends on the frequency of the current that flows through the converter. As the current contains the fundamental and third-harmonic capacitor voltage will Hz frequency component to reduce this ripple. One the single-phase converter to reduce the flows into the converter. capacitor with a larger



frequency component, the dc-contain 100-, 200-, and 300-. There are two possible ways is to increase the turn ratio of transformer of the series magnitude of the current that The other way is to use the dc capacitance.

C. Shunt Control

The block diagram of the shown in Fig. 16.

The objective of the shunt control is to inject a constant third harmonic current into the line to provide active power for the series converters. The third-harmonic current is locked with the bus voltage at the fundamental frequency. A PLL is used to capture the bus-voltage frequency, and the output phase signal of the PLL is multiplied by three to create a virtual rotation reference frame for the third-harmonic component. The shunt converter's fundamental frequency control aims to inject a controllable reactive current to grid and to keep the capacitor dc voltage at a constant level. The control for the fundamental frequency components consists of two cascaded controllers. The current control is the inner control loop, which is to modulate the shunt current at the fundamental frequency. The q-component of the refer ence signal of the shunt converter is obtained from the central controller, and d-component is generated by the dc control.

shunt converter control is

Fig. 17. DPFC experimental

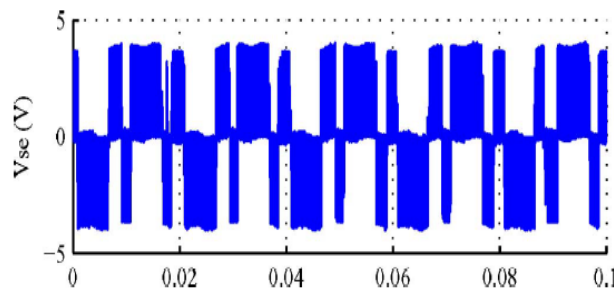

setup circuit.

Fig. 18. DPFC experimental setup.

V. LABORATORY RESULTS

An experimental setup has been built to verify the principle and control of the DPFC. One shunt converter and six single-phase series converters are built and tested in a scaled network, as shown in Fig. 17. Two isolated buses with phase difference are connected by the line. Within the experimental setup, the shunt converter is a single-phase inverter that is connected between the neutral point of the Y- Δ transformer and the ground. The inverter is powered by a constant dc-voltage source. The specifications of the DPFC experimental setup are listed in the Appendix (see Table I).

Within the setup, multiple series converters are controlled by a central controller. The central controller gives the reference voltage signals for all series converters. The setup are measured by an in computer by using the of the DPFC experimental

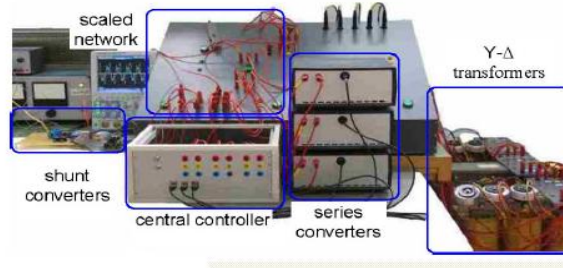

principle, two situations are behavior in steady state and the state, the series converter is vector with both d- and q- $V_{se,d,ref} = 0.3 \text{ V}$ and $V_{se,q,ref} = -0.1 \text{ V}$. Figs. 19–21 show one operation point of the DPFC setup. For clarity, only the waveforms in one phase are shown. The voltage injected by the series converter, the current through the line, and the voltage and current at the Δ side of the transformer are illustrated.

Fig. 19. DPFC operation in steady state: line current.

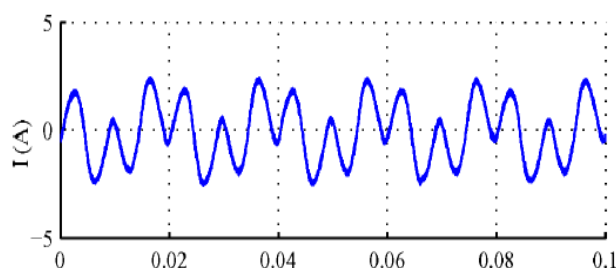

Fig. 20. DPFC operation in

voltage.

steady state: series converter

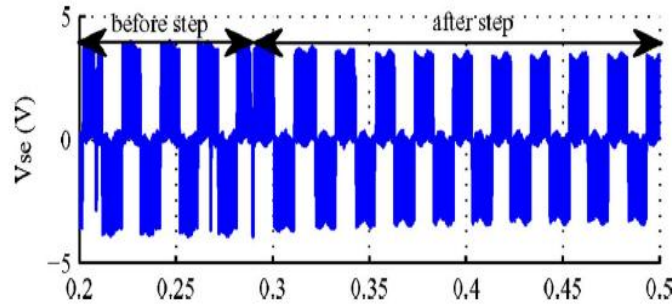

Fig. 21. DPFC operation

in steady state: bus voltage

the transformer.

and current at the of

The constant third-harmonic current is injected by the shunt converter evenly and is superimposed on the fundamental current in Fig. 19. The voltage injected contains two frequency components. The amplitude of the waveform represents the dc voltage well maintained by the third-harmonic filtering by the Y-Δ transformers. There is no third-harmonic current or voltage leaking to the Δ side of the transformer.

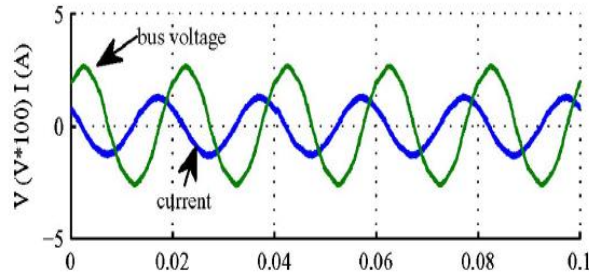

harmonic current injected by the series converter also disperses to the three phases fundamental current, as shown by the series converter also components in Fig. 20. The pulsewidthmodulated (PWM) capacitor voltage, which is harmonic component in steady state

The DPFC controls the power flow through transmission lines by varying the voltage injected by the series converter at the fundamental frequency. Figs. 22–26 illustrate the step response of the experimental setup. A step change of the fundamental reference voltage of the series converter is made, which consists of both active and reactive variations, as shown in Fig. 22.

As shown, the dc voltage of the series converter is stabilized before and after the step change. To verify if the series converter can inject or absorb active and reactive power from the grid at the fundamental frequency, the power is calculated from the measured voltage and current in Figs. 23 and 24. The measured data in one phase are processed in the computer by using MATLAB. To analyze the voltage and current at the fundamental frequency, the measured data that contains harmonic distortion are filtered by a low-pass digital filter with the 50-Hz cutoff frequency. Because of this filter, the calculated voltage and current at the fundamental frequency have a 1.5 cycle delay to the actual values, thereby causing a delay of the measured active and reactive power. Fig. 25 illustrated the active and reactive power injected by the series converter. A comparison is made between the measured power and the calculated power. We can see that the series converters are able to absorb and inject both active and reactive power to the grid at the fundamental frequency.

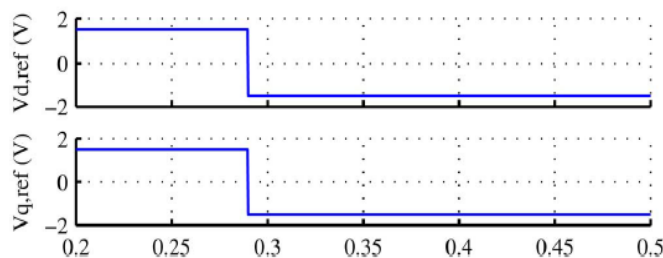

Fig. 22. Reference voltage

for the series converters.

Fig. 23. Step response of the DPFC: series converter voltage.

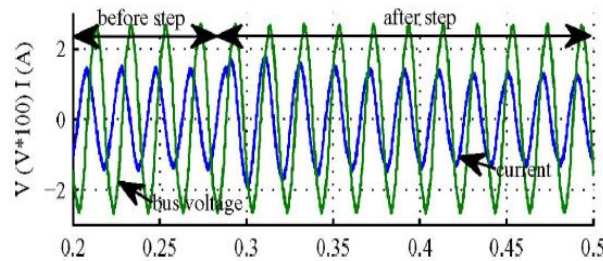

Fig. 24. Step response of the

DPFC: line current.

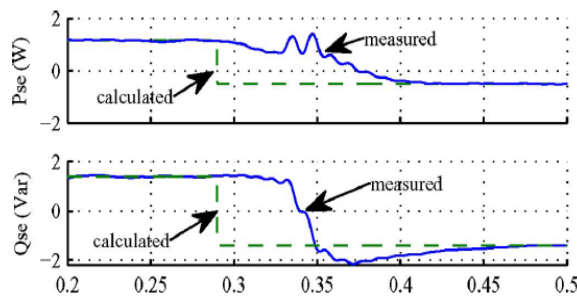

Fig. 25. Step response of the injected by the series converter at the

DPFC: active and reactive power fundamental frequency.

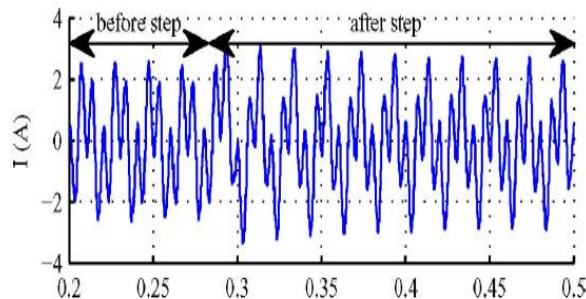

Fig. 26. Step response of the the Δ side of the transformer.

DPFC: bus voltage and current at

VI. CONCLUSION

This paper has presented a new concept called DPFC. The DPFC emerges from the UPFC and inherits the control capability of the UPFC, which is the simultaneous adjustment of the line impedance, the transmission angle, and the bus-voltage magnitude. The common dc link between the shunt and series converters, which is used for exchanging active power in the UPFC, is eliminated. This power is now transmitted through the transmission line at the third-harmonic frequency. The series converter of the DPFC employs the D-FACTS concept, which uses multiple small single-phase converters instead of one large-size converter. The reliability of the DPFC is greatly increased because of the redundancy of the series converters. The total cost of the DPFC is also much lower than the UPFC, because no high-voltage isolation is required at the series-converter part and the rating of the components of is low. The DPFC concept has been verified by an experimental setup. It is proved that the shunt and series converters in the DPFC can exchange active power at the third-harmonic frequency, and the series converters are able to inject controllable active and reactive power at the fundamental frequency.

TABLE I
 SPECIFICATION OF THE DPFC EXPERIMENTAL SETUP

Symbol	Description	Value	Unit
V_s	nominal voltage of grid s	220	V
V_r	nominal voltage of grid r	220	V
θ	transmission angle between grid s and r	1	°
L	line inductance	6	mH
$V_{sh,max}$	shunt converter maximum ac voltage	50	V
$I_{sh,max}$	shunt converter maximum ac current	9	A
$V_{sh,dc}$	shunt converter dc source supply	20	V
$I_{sh,ref,3}$	reference 3 rd harmonic current injected by the shunt converter	3	A
f_{sw}	switching frequency for the shunt and series converter	6	kHz
$V_{sc,max}$	maximum ac voltage at line side of the series converter	7	V
$I_{sc,max}$	maximum ac current at line side of the series converter	15	A

REFERENCES

[1] Y.-H. Song and A. Johns, Flexible ac Transmission Systems (FACTS) (IEE Power and Energy Series), vol. 30. London, U.K.: Institution of Electrical Engineers, 1999.

[2] N. G. Hingorani and L. Gyugyi, Understanding FACTS: Concepts and Technology of Flexible AC Transmission Systems. New York: IEEE Press, 2000.

[3] L. Gyugyi, C. D. Schauder, S. L. Williams, T. R. Rietman, D. R.Torgerson,and A. Edris, “The unified power flow controller: A new approach to power transmission control,” IEEE Trans. Power Del.,vol. 10, no. 2, pp. 1085–1097, Apr. 1995.

[4] A.-A. Edris, “Proposed terms and definitions for flexible ac transmission system (facts),” IEEE Trans. Power Del., vol. 12, no. 4, pp. 1848–1853,Oct. 1997.

[5] K. K. Sen, “Sssc-static synchronous series compensator: Theory, modeling, and application,” IEEE Trans. Power Del., vol. 13, no. 1, pp. 241–246,Jan. 1998.

[6] M. D. Deepak, E. B. William, S. S. Robert, K. Bill, W. G. Randal, T. B. Dale, R. I. Michael, and S. G. Ian, “A distributed static series compensator system for realizing active power flow control on existing power lines,” IEEE Trans. Power Del., vol. 22, no. 1, pp. 642–649, Jan.2007.

[7] D. Divan and H. Johal, “Distributed facts—A new concept for realizing grid power flow control,” in Proc. IEEE 36th Power Electron. Spec. Conf. (PESC), 2005, pp. 8–14.