

An Overview of PLC Based Control Panel System for External Plunge Grinding Machine and CNC Machine

Arvind N. Nakiya¹, Mahesh A. Makwana²

¹(Department of Electrical Engineering, Nirma University, Ahmedabad, India

²(Department of Mechanical Engineering, Sardar Vallabhbhai National Institute of Technology, Surat, India

ABSTRACT: Automation is the process of handling various parameters of process like temperature, flow, level etc. without presence of responsible person. In industrial field, Automation and control have greatly improve in industrial manufacturing in the world Technological advancement in automation and control over the past decades have contributed greatly to improve the productivity of virtually all manufacturing industries throughout the world. In the development of automation controllers the trend has been to move towards soft controllers so as to provide better control, more flexibility and more reliability with intelligent diagnostics of machine faults. So industries have gradually moved from conventional relay logic control to programmable logic control and then to computerized numeric control. In this paper all the required control and motor performance data will be taken to a personal computer via PLC for further analysis. Various results are obtained and discussed.

Keywords: Computerized Numeric Control (CNC), External plunge Grinding machine (EPG), Personal Computer (PC), Programmable Logic Controller (PLC), Pulse per revolution (ppr)

I. INTRODUCTION

Almost any production line, machine function or process can be automated using a PLC. The speed and accuracy of the operation can be greatly enhanced using this type of control system. But the biggest benefit in using a PLC is the ability to change and replicate the operation or process while collecting and communicating vital information. Since there were problems related to large electrical panels with a number of electrical components and extensive wiring, people felt the need for software logic controllers? So they gave birth to Programmable Logic Controller (P.L.C) wherein the control logic is developed in ladder diagram, a software logic control, with a number of inputs taken from the environment and generating the outputs, depending on the logic programmed, to the environment. This helped to control any machine sequence with small electrical panels, less number of electrical components and less wiring with more flexibility to change machine sequence. These fulfilled some of their needs but the desire to obtain software controlled automation with accuracy necessitated the development of Computer Numeric Control (C.N.C). In order to have better control for positioning, controlled speed and quick reversal of direction of slide movement, servo motors having less inertia, along with servo drives are interfaced with the C.N.C. The user based part program decoded by the C.N.C. provides the desired profile with the control being transferred to P.L.C. and drives as and when required. Special measuring devices

as locators, gauges being interfaced with the C.N.C. through independent controllers provide more accuracy. [1]

Advantages of PLC are as below;

- Reliability in operation
- Flexibility in control techniques
- Flexibility in programming
- Large quantity of contacts
- Online/offline modifications
- Cost effective for controlling complex systems
- Small physical size, shorter project time
- In-house simulation and testing of project
- Speed in operation
- Ability to communicate with computer systems
- Security [2]

II. PROGRAMMABLE LOGIC CONTROLLER

2.1 A programmable logic controller is a specialized computer. Since it is a computer, it has all the basic component parts contained in any other computer, a central processing unit, memory, input interfacing, and output interfacing.

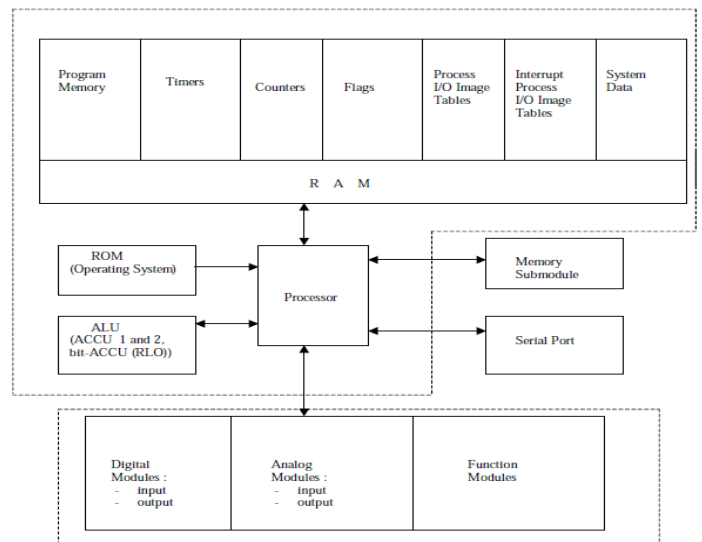

Fig.1 functional units of a typical PLC

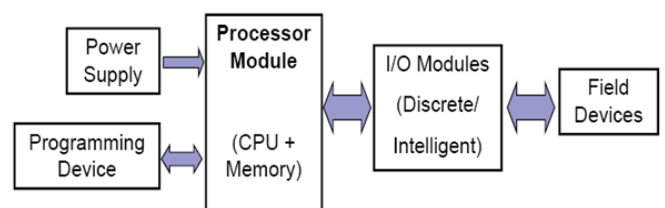

Fig.2 Block Diagram of PLC

The block diagram of Programmable Logic Controller is shown in Fig.2 The processor is a solid state

device designed to replace relays, timers, counter etc. The necessary voltage and current requirement for the internal working of the PLC is generated by the power supply. The field element is interfaced to the input or output section. Typical input or output section, typical input element are push buttons, limit switches, proximity switches, relay contacts, selector switches, thumb wheels etc. Typical output elements are solenoid valves relay coils, indicator lights LED display etc.



Fig.3 PLC based control panel for EPG

Fig.3 shows PLC based control panel system for external plunge grinding machine. In this control panel system Mitsubishi Q series PLC is used. PLC controls all inputs and outputs. Wheel is fed directly into the work piece in external plunge grinding. In this paper external plunge grinding is used for bearing application.

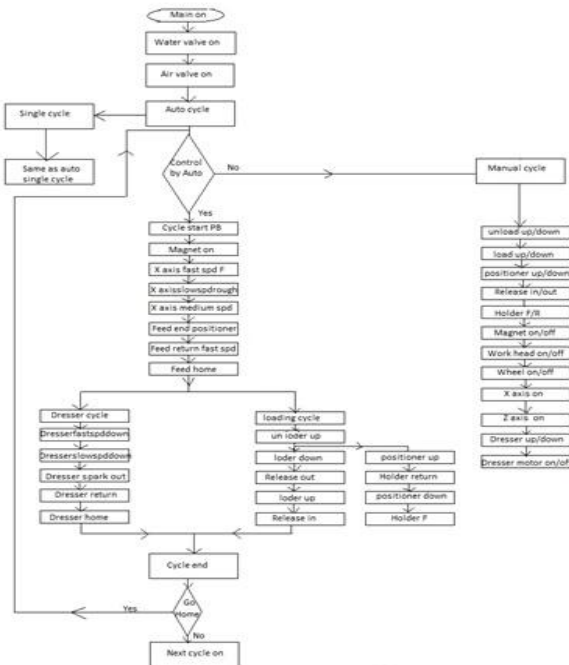

Fig.4 Flow chart of EPG machine

Operation of machine is done by three cycles. Single cycle, multi cycle and manual cycle. Machine operation is done in manual and auto both modes. In auto cycle one cycle is over the next cycle is automatic on.

2.2 Computer Numeric Control (CNC): The major components associated with a CNC system are power supply, PLC, servo drives, Touch monitor and keyboard and some special controllers might be interfaced for specific accuracy requirements such as precise positioning of job, accurate sizing of any machining operations. The power unit supplies constant 24V D.C. to the system. PLC interfaced with the CNC is programmed for the machine sequence. The part program of the CNC determines the operational sequence of the machine. To clarify the machine sequence and operational sequence CNC-PLC interface has been dealt later in this paper. Servo drives are used in conjunction with servo motors for better variable speed control with less response time as the inertia of the rotor is less. The diagram (1) has shown below shows the CNC block diagram with the necessary interfaces for a single axis machine [3].

There are two types of servo drives:

- (1) Constant torque-speed drives used for axis motors
- (2) Constant power drives used for spindle motors

The external inputs and outputs from the machine are connected to the PLC through the I/O interface of PLC. The system program of the CNC executes the part program, reads the machine data, perform the calculations.

CNC reads in the signal from the axis encoder from the measuring card which is placed in one of the slots of the controller. Thus having the machine data as pitch of the ball-screw, number of encoder pulses generated and resolution of the encoder mounted on the slide the distance moved by the slide can be calculated as [4].

Distance = $(p/r) * e_p$ (here backlash compensation is not taken into account)

Where p = pitch of ball-screw (mm)

r = resolution of encoder in (ppr)

e_p = number of encoder pulses generated

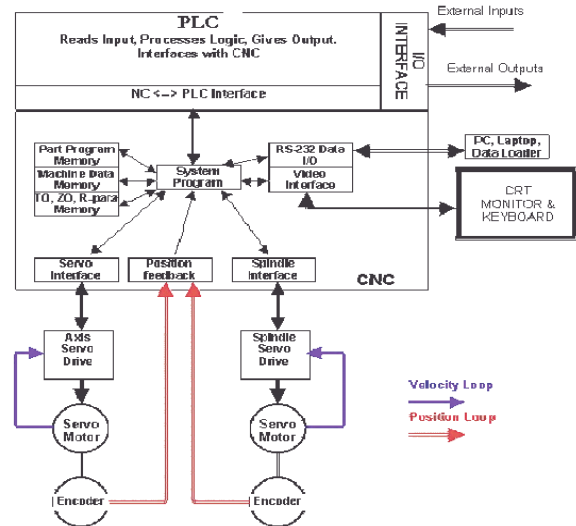

Fig. 5 CNC block diagram

This provides the positional feedback to the system. The velocity feedback is directly fed to the drive from the encoder or tachogenerator of the servo motor. The diagram (5) below shows the interface of the CNC with the servo drives. CNC sends a drive enable signal to a drive and the drive tends to retain its position unless some command for movement is send from the CNC. To give feed command CNC along with the drive enable signal sends a reference

voltage to the drive in the range of +/-10V proportional to the desired speed. The +/- sign denotes the direction of movement [5].

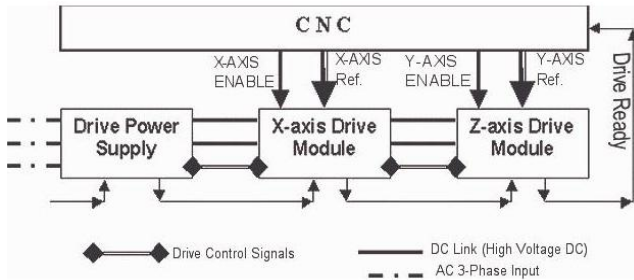

Fig 6 Drive-CNC interface diagram

The reference voltage is calculated as:

$$\text{Reference voltage} = (10/n) * S$$

Where n = maximum speed i.e. rated speed of motor (r.p.m)

S = desired speed (r.p.m)

The drive calculates the commanded speed from the reference voltage and calculates the actual motor speed from the motor encoder feedback to the drive. Thus the error is known and by changing the frequency and phase voltage drive tries to minimize the error to maintain the desired speed. If the drives and motors are in healthy condition then a drive ready signal is send to the PLC. If this signal is missing then fault appears and axes movements or spindle operations are not possible.

III. EXPERIMENTAL RESULT

Many PLC processors have an RS-232 port that is normally used for programming the PLC. The RS-232 standard is based on a low/false voltage between +3 to +15V, and a high/true voltage between -3 to -15V (+/-12V is commonly used). Fig.7 shows the experimental result of output of hydraulic machine derived by GT-Developer software.

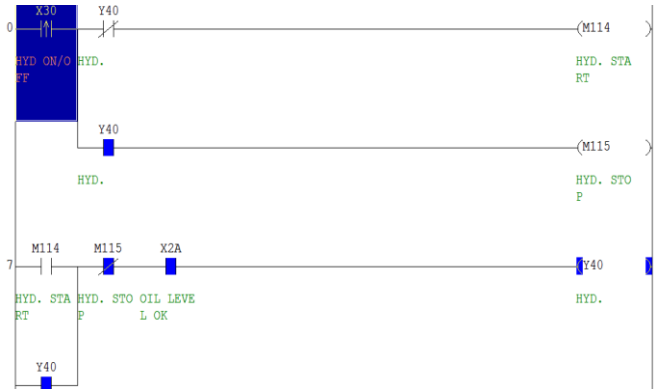

Fig. 7 Experimental result

IV. CONCLUSION

The paper gives a broad overview of PLC and CNC controllers in machine automation and grinding application. Certain other factors are also involved but it could not be presented in this paper. However the topics dealt with will give a brief idea for the basic functioning of PLC and CNC controllers. By automation we can improve the productivity in the industry. We continuously monitor the state of input devices and make the decision based upon a custom program to control the state devices connected as output.

REFERENCES

- [1] Pradeep Chatterjee, An over view of PLC and CNC in machine automation.
- [2] Bolton, w., Programmable Logic Controllers: An Introduction, Butterworth-Heinemann, 1997.
- [3] Douglas V. Hall, Microprocessors and Interfacing (Programming and Hardware), Tata McGraw-Hill, 1992.
- [4] Pradeep Kumar srivastava, Programmable logic controllers.
- [5] K.V Ram, a Course of CNC Maintenance.