

## Computer-Aided Optimal Design and Finite Element Analysis of a Plain Milling Cutter

K. Lalitha Babu<sup>1</sup>, M. Kumara Swamy<sup>2</sup>

<sup>1</sup>PG student, Department of Mechanical Engineering, University College of engineering

<sup>2</sup>Department of Mechanical Engineering, University College of engineering, JNTUK- Kakinada, A.P, INDIA

**Abstract:** Plain Milling is one of the progressive enhancements of miniaturized technologies which have wide range of application in industries and other related areas. Plain milling cutters are widely used in roughing and finishing of parts. The milling cutter geometry and distribution of inserts on the cutter body vary significantly in industry depending on the application. This paper presents a generalized mathematical model of plain milling cutter for the purpose of predicting cutting forces, dimensional surface finish, stress, and strain. A sample of plain milling cutter modeling and analysis examples are obtained by using the design and analysis is carried out using the software's like CATIA V5 and ANSYS.

Milling like any metal cutting operation is used with an objective of optimizing surface roughness at micro level and economic performance at macro level. In addition to surface finish, modern manufacturers do not want any compromise on the achievement of high quality, dimensional accuracy, high production rate, minimum wear on the cutting tools, cost saving and increase of the performance of the product with minimum environmental hazards. In this Paper the design aspects of plain milling cutter is analyzed. The objective considered is the design and modeling of plain milling cutter and to analyse various stress components acting on it. Various designing strategies are considered to design the effective plain milling cutter like outer diameter, inner diameter, radius, teeth angle etc.

**Keywords:** ANSYS, CATIA, Cutter, High Speed Steel, Plain Milling, Speed

### I. Introduction

Modeling and simulation of machining processes is a critical step in the realization of high quality machined parts. To precisely simulate the machining operations, accurate models of cutting tools used in the machining processes are required. In metal cutting industry, a plain mill cutter plays an important role for obtaining the desired shape and size of a component. [1]. A variety of helical end mill cutters are used in the industry. Helical cylindrical, helical slab, taper helical and special purpose plain mills are widely used in aerospace, automotive and die machining industries. The analysis of the geometry of the tool surfaces and cutting flutes along with the cutting forces acting on the plain mill plays an important part in the design of the plain mill and the quality of the manufacturing process. Traditionally, the geometry of cutting tools has been defined using the principles of projective geometry. Constantly growing competition between all manufacturers on the global market leads, among the others, to important requirements concerning improving both machining accuracy and economic efficiency of manufacturing [2] this competition is very intense in the case of various products in aviation industry.

### II. Milling cutters

Classification of milling cutters according to their design, HSS cutters like end mills, slitting cutters, slab cutters, angular cutters, form cutters and many cutters are made from high-speed steel (HSS)[8]. Brazed cutters are Very limited numbers of cutters (mainly face mills) are made with brazed carbide inserts. This design is largely replaced by mechanically attached cutters. Mechanically attached cutters are the vast majority of cutters in this category [3]. Carbide inserts are either clamped or pin locked to the body of the milling cutter. Basically, milling operations are divided in to peripheral milling, Face milling and Plain milling. The End milling process is widely used in industry because of versatility and effectiveness.

[4] The plain Mill has edges in the side surface and the bottom surface. During the operation in plain milling, vibration is considered to be one of the most important while machining. Three different types of mechanical vibrations such as free vibrations, forced vibrations and self-excited vibrations that arise due to the lack of dynamic stiffness, stability of the machine parts, vibrations generated under unsuitable cutting conditions creates serious problem as it causes excessive tool wear, noise, tool breakage, and deterioration of the surface quality. The milling cutter is a multiple point cutting tool. The cutting edge may be straight or in the form of various contours that are to be reproduced upon the work piece. The relative motion between the work piece and the cutter may be either axial or normal to the tool axis. In some cases a combination of the two motions is used. [5] For example, form-generating milling cutters involve a combination of linear travel and rotary motion. The figure below shows the various angles and geometry of a milling cutter.

#### 2.1 Types of milling operations:

Owing to the variety of shapes possible and its high production rates, milling is one of the most versatile and widely used machining operations. The geometric form created by milling fall into three major groups:

- Plane surfaces: the surface is linear in all three dimensions. The simplest and most convenient type of surface;
- Two-dimensional surfaces: the shape of the surface changes in the direction of two of the axes and is linear along the third axis. Examples include cams;

- Three-dimensional surfaces: the shape of the surface changes in all three directions. Examples include die cavities, gas turbine blades, propellers, casting patterns, etc. [6]

All of these classifications can have either a vertical or horizontal spindle configuration.

### 2.2 Plain milling cutter Nomenclature:

The nomenclature of a plain milling cutter is shown in the figure (1).

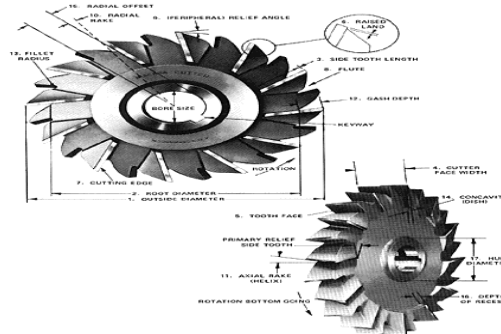

Figure 1: Nomenclature of plain milling cutter

### III. Finite Element Analysis of Plain milling cutter

In order to perform a finite element analysis, it is necessary to determine the forces acting on the cutter. From the given conditions the force acting on the cutter (W) may be calculated as:

$$W = \frac{60,000H}{\pi Dn} \quad \text{- Equation (1)}$$

where H is the power, in kW, n is the speed, in rpm, and D is the diameter of the cutter. The stress calculation at the tip of the tooth of the cutter is estimated based on the concept of gear tooth stresses. The stress at each speed is determined by [7]:

$$\sigma = \frac{6Wl}{Ft^2} \quad \text{- Equation (2)}$$

The maximum allowable stress at the tip of the cutter is determined as:

$$\sigma_{\text{allowable}} = \frac{S_t K_L}{K_T K_R} \quad \text{-Equation (3)}$$

$S_t$  (AGMA bending strength) = 44,000 psi

$K_R$  (reliability factor) = 1

Whereas:  $K_L$  (life factor) = 1

### IV. Dimensions of a Plain Milling Cutter:

The various dimensions chosen for the cutter are shown in figure (2)

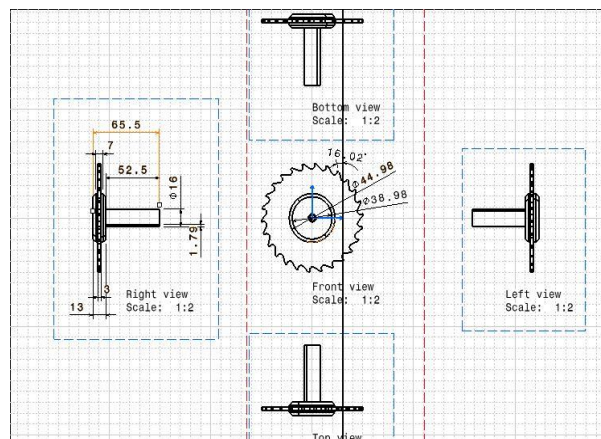

Figure 2: Dimensions of Plain milling cutter

### V. Material Properties:

High Speed steel is the material chosen for the milling cutter and the properties are tabulated in Table 1:

Tensile strength (Mpa)	900/1000
Young Modulus E (Mpa)	200000/210000
Compressive Strength(Mpa)	3000/3200
Ductility(compression) %	8/10
Thermal Expansion <sup>o</sup> C	11.5/11.8
Thermal Conductivity(W/m k)	17/18
Specific Heat (J/Kg K)	500/540

Table 1: Properties of High speed Steel milling cutter

From the above data plain milling cutter is designed using CATIA and then model will be analysis by using ANSYS software.

### VI. Modeling of Plain Milling Cutter using CATIA:

CATIA V5 is used to model the plain milling cutter and various views are presented in Fig. (3)

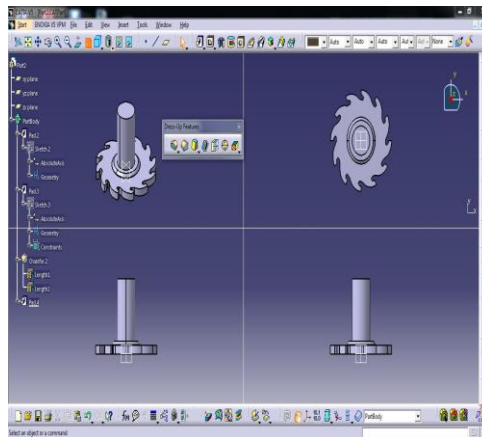

Fig. (3) 3D view of the plain milling cutter.

### VII. Analysis of Single Tooth using ANSYS:

The Cutting Forces (loads) on the cutter for five different speeds are calculated (Refer Table.2) and the same are applied on the tip of the cutter modal. The variation in stresses and strains on cutter from ANSYS are Shown in Fig.4.The results are tabulated in Table 2.

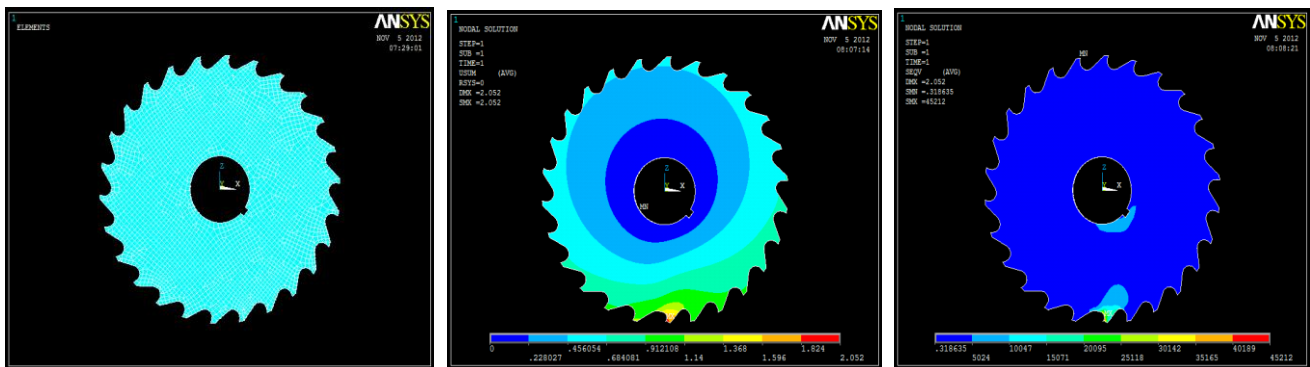

Fig.4(a) Meshed modal of 3D profil Fig.4 (b) Deformation of the cutter at 50 rpm Fig.4(c) Stress at speed 50 rpm

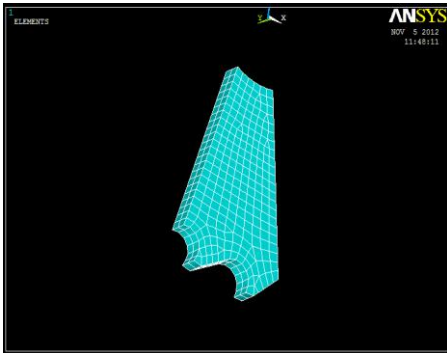

Fig.4 (d) Meshed model of single tooth profile

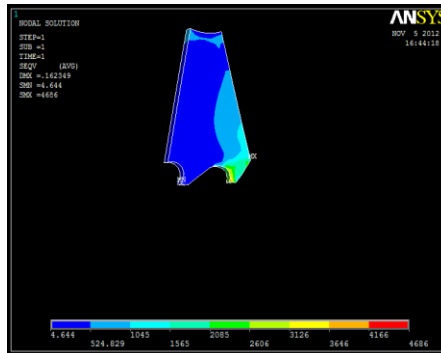

Fig.4 (e) Stress plot at 50 rpm

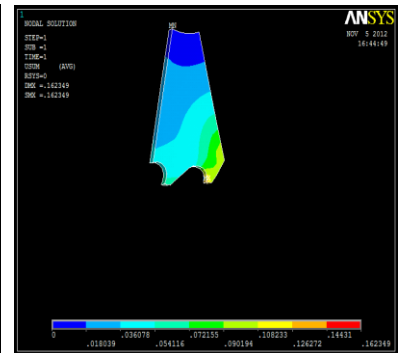

Fig.4 (f) Deformation at 50 rpm

S.no	DI A	SPEED	LOAD	STRESS (Model)	STRESS (Theoretical)
1	100	50	2101.911	4521	4056
2	100	100	1050.955	2261	2207.6
3	100	500	210.1911	2243	2220.8
4	100	1000	105.0955	226.049	223.5
5	100	2000	52.54777	112.485	108.19

Table 2: Results obtained from the analysis

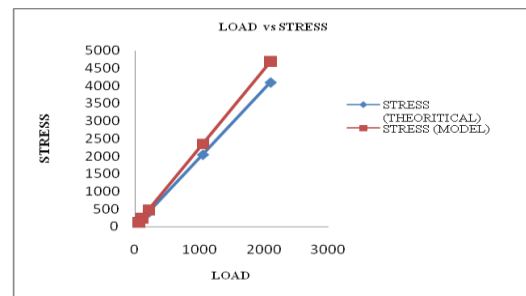

Figure 5: Plot Load Vs Stress

Represents the graph between different loads with model, and theoretical stress

### VIII. Conclusion

The main objective of this study has been to perform a detailed computer-aided design and analysis of a plain milling cutter by integrating solid modeling and finite element analysis. Any cutter, single point or multiple point, can be designed based on the approach presented here. It could even be ventured that this approach can be used to design any complex mechanical component or system. Specifically for the cutter design, it produced the cutting variables that yield the minimum cost of manufacturing. The different design activities, such as design solid modeling, and finite element analysis, have been integrated. As is evident, approach presented in this paper is flexible and easy to use. Finally the design and analysis is carried out using the software’s CATIA V5 and ANSYS. The values obtained are compared with the model and theoretical stress values of the plain milling cutter

### IX. Acknowledgment

I would like to thank my Guide, Associate Professor Mr.M.KUMARA SWAMY for his time and support. In addition, I would like to thank my friends for sharing their experience in CATIA, ANSYS. Finally, I would like to thank my family for their support and putting up with me for these past few months moral and financial support during my studies.

### References

- [1] N and K. Jha and Kathryn Hornik, “Integrated computer-aided optimal design and FEA of a plain milling cutter”, Mechanical Engineering Department, Manhattan College, Riverdale, NY, USA
- [2] E. Abele, Y. Atlantis, and C. Brasher, “Machine tool spindle units”, CIRP Annals – Manuf. Technol., vol. 59, pp. 781-802, 2010.
- [3] C. Li, Y. Ding, and B. Lu, “Development and Key Technology in High Speed Cutting”, J. Qingdao Technol. Univ., vol. 30, pp. 7-16, Feb. 2009.
- [4] Kronenberg, M. Machining Science and Application. Pergamon Press, 1966
- [5] ASTME. Fundamentals of Tool Design, 1985
- [6] Draghici, G. and Paltinea, C. Calculation by convex mathematical programming of the optimal cutting condition when cylindrical milling. Int. J. Mach tool Des. Res. xxxx, 14, 143-160
- [7] Shigley, J.E. and Mischke, C.R. Mechanical Engineering Design, Fifth Edition. McGraw Hill book Company, 1989.
- [8] A text book of Machine design R.S Khurmi, and J.K Gupta. 2008 edition S.Chand publications.