

## Low Cost Self-assistive Voice Controlled Technology for Disabled People

R. Puviarasi<sup>1</sup>, Mritha Ramalingam<sup>2</sup>, Elanchezhian Chinnavan<sup>3</sup>

<sup>1</sup>(Asst.Prof., Department of Electrical and Electronics Engineering, Saveetha University, India

<sup>2</sup>(Lecturer, School of Engineering, AIMST University, Malaysia)

<sup>3</sup>(Lecturer, School of Physiotherapy, AIMST University, Malaysia)

**ABSTRACT:** This paper describes the design of an innovative and low cost self-assistive technology that is used to facilitate the control of a wheelchair and home appliances by using advanced voice commands of the disabled people. This proposed system will provide an alternative to the physically challenged people with quadriplegics who is permanently unable to move their limbs (but who is able to speak and hear) and elderly people in controlling the motion of the wheelchair and home appliances using their voices to lead an independent, confident and enjoyable life. The performance of this microcontroller based and voice integrated design is evaluated in terms of accuracy and velocity in various environments. The results show that it could be part of an assistive technology for the disabled persons without any third person's assistance.

**Keywords:** Disabled people, Home automation, Self-assistive, Voice control, Wheel chair,

### I. INTRODUCTION

Sometimes low-technology devices are the most appropriate and even preferred for their simplicity, ease of use, maintenance, and low cost. Naturally, a wheelchair voice control system should operate reliably for a large number of users, reduce the physical requirements; and if avoiding the need to move on one or more road extremities, should assist a user in maintaining well the chair position. However, the limited bandwidth of the voice makes it difficult to adjust frequently with the wheelchair's velocity, and also a voice input system may fail to identify a speaker. Thus, voice interface has yet become commercially viable for wheelchair control [1]. However, one implementation difficulty is that a voice input system may fail to recognize a user's voice. Indeed, speech activated interface between human and autonomous/semi-autonomous systems requires accurate detection and recognition. So the pitch and end-point detection plays an important role in speech recognition system [2]. The current power wheelchair control interfaces used may not be adequate to provide truly independent mobility for substantial number of person with disabilities [3]. The Respondents to the survey reported on average that approximately ten percent of the patients trained to operate a power wheelchair cannot use the chair upon completion of their training for activities of daily living or can do so only with extreme difficulty. The design and development of a speech recognition system can be used to interact with a home computer and to control domestic appliances at the command of a word (speech) [4]. The voice received is processed in the voice recognition system where the feature of the voice command is extracted and matched with the existing sample in the database. The module recognizes the voice and sends control messages to the microcontroller [5, 6]. Powered wheelchair users often struggle to drive safely and effectively and in more critical cases can only get around when accompanied by an assistant [7]. Without assistance, participants experienced multiple collisions whilst driving around the predefined route. These issues are proposed in a collaborative control mechanism that assists the user as and when they require help. The basic idea of the driving assistance module is to detour obstacles in a way that is most likely to be acceptable for the user. The automated wheel chair using head joystick [8] produces the driving assistance module by altering the translational and rotational velocities. A paper focuses specifically on the evaluation of shared control methodologies [9] surveys many components of wheelchair design: everything from mechanical aspects, interfaces and control algorithms to ISO standards that are being developed to assist users in driving safely.

The proposed system enables physically challenged persons like paralytic patients or physically disabled patients or patients having acute diseases like Parkinson's disease, to facilitate the control of a wheelchair. In particular, this is useful for the persons where they can move their wheelchair in their own directions, without any third party's help or support. The objective of this paper is divided into two targets. One is to control various home appliances by voice, and the other is to enable severely disabled person's movement independently using voice activated powered wheelchair, that provide reliability, safety and comfort. Moreover, home automation is an absolute benefit and can improve the quality of life for the user. Wheelchairs provide unique mobility for the disabled and elderly with motor impairments. The designed system is based on grouping a microcontroller with a new voice recognition processor. The rest of the paper is organised as follows. After the introduction, Section 2 presents the design method. Section 3 discusses the experimental results and performance evaluation of the proposed design. Section 4 concludes the paper.

### II. DESIGN METHOD

In the proposed design, the main idea of using voice activated technology for controlling the motion of the wheelchair and home automation is to prove that it can be an unique solution for severely disabled. The use of this new technology in conjunction with a mechanical system is, in order to simplify everyday life would spark interest in an ever growing modern society. Many people with disabilities do not have the dexterity necessary to control a joystick on an

electrical wheelchair. This can be a great drawback for the quadriplegics who is permanently unable to move any of the arms or legs. They can use their wheelchair easier only using voice commands and also they can control their home appliances. The aim of this study is to implement an interesting application using small and advanced vocabulary word recognition system. The methodology adopted is based on grouping a microprocessor with a speech recognition development kit for isolated word from a dependent speaker. The resulting design is used to control a wheelchair and home appliances for a disabled person based on the vocal command. It therefore involves the recognition of isolated words from a limited vocabulary. There are seven options for basic motions of a wheelchair & home appliances control to be applied by the user. The seven conditions of the wheelchair can be described as the following: moving forward to the front of the user, moving backward to the back of the user, turning to the right, turning to the left, static or stop condition, light on and light off

### 2.1 Mechanical and Electrical Design of the wheel chair

In this section, the manual wheelchair is modified into an electrical wheelchair which is controlled using voice command. The important part is to upgrade the manual wheelchair into an electrical wheelchair. Thus, the parts like motors, pulleys, belts and a battery are needed. With the combination of these mechanical and electrical parts, the manual wheelchair now is turned to be an electrical wheelchair. There are a number of possible driving wheel configurations (front wheel drive, rear wheel drive and mid wheel drive) which affect the characteristics of the chair in different situations, with turning while driving being the most complex. Further features can be added to assist the user such as lights, actuators and wireless links. The heart and brains of the powered wheelchair is in the controller as it provides both a conduit for the power to the motors and controls the overall system. The wheel which is connected with the motor is considered as the main wheel. The main wheel is 6" in diameter. Fig.1 (a) shows the main wheel that has a single bore at the centre. This bore is connected to the motor. A caster (or castor) wheel shown in Fig.1 (b) is an un driven, single, double, or compound wheel that is designed to be mounted to the bottom of a larger object (the "vehicle") so as to enable that object to be easily moved.

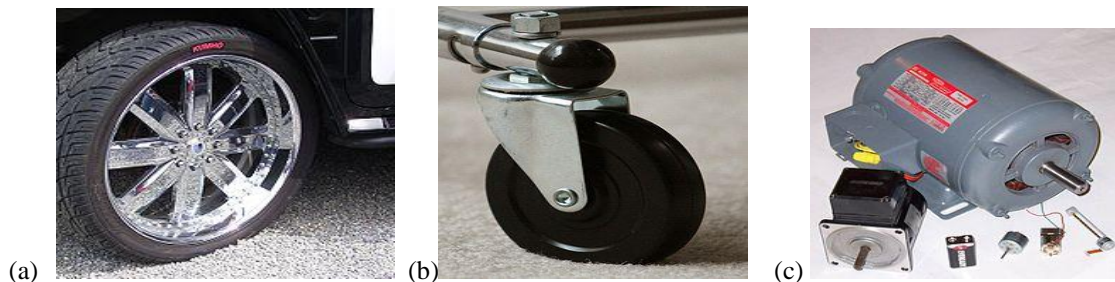

Figure 1. (a) Main wheel (centre bore) (b) caster wheel (c) DC motor

This section mainly deals with the electrical components used in controlling the wheelchair and home automation. A DC motor shown in Fig.1 (c) is an electric motor that runs on direct current (DC) electricity. DC motors can operate directly from rechargeable batteries, providing the motive power for the vehicles. Today DC motors are still found in applications as small as toys and disk drives, or in large sizes to operate steel rolling mills and paper machines. Also step-down transformer, filter capacitors, rectifiers, transmitter-receivers are used in the system design. Fig.2 shows the basic components used in the design of the voice controlled wheel chair.

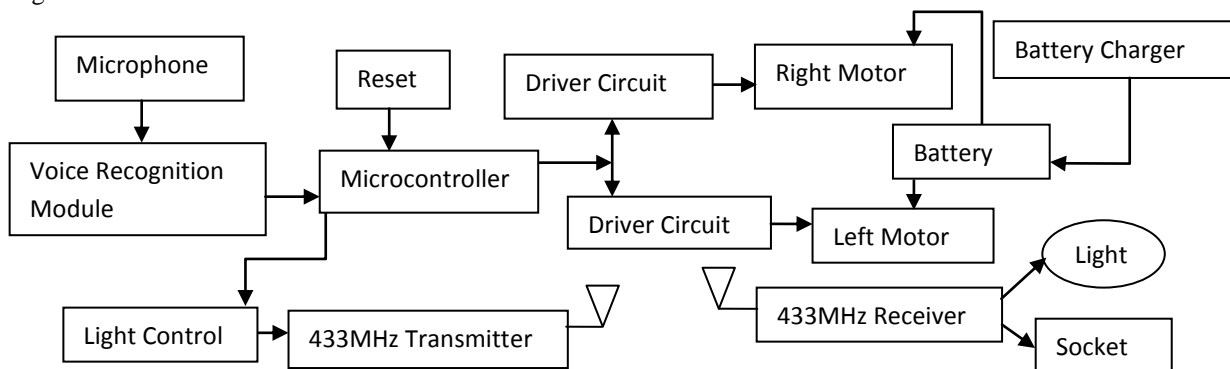

Figure 2. Basic Components of Wheelchair

### 2.2 Interfacing Circuits Design of wheel chair

The block diagram of the interfacing circuit of the wheel chair is shown in Fig 3. In this circuit, the HM 2007 processor is assembled with the input and output port, memory chip and the digital display. The instructions given by the supplier must be followed carefully so that the system can work properly. The voice recognition circuit operates as the main part of the system to store the commands in to the HM2007 processor. This speech recognition system uses a simple keypad and digital display to communicate with and program the HM2007 processor. When the circuit was turned on, the processor will check the static RAM. After this check out, the board displays "00" on the digital display and lights the red LED (READY). It is in the "Ready" state waiting for the command. In this system, the display board will be taking off from the output of voice recognition circuit and replace it by the interfacing circuit which will be connected to the motor driven

circuit. This is initialized by pressing the word number that wanted to be trained on the keypad. The circuit can be trained to recognize up to 40 words. The HM 2007 processor is assembled with the input and output port, memory chip and the digital display. The instructions given by the user must be followed carefully so that the system can work properly.

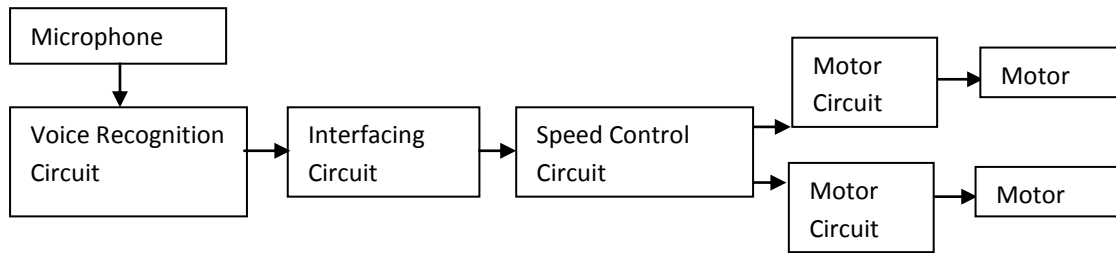
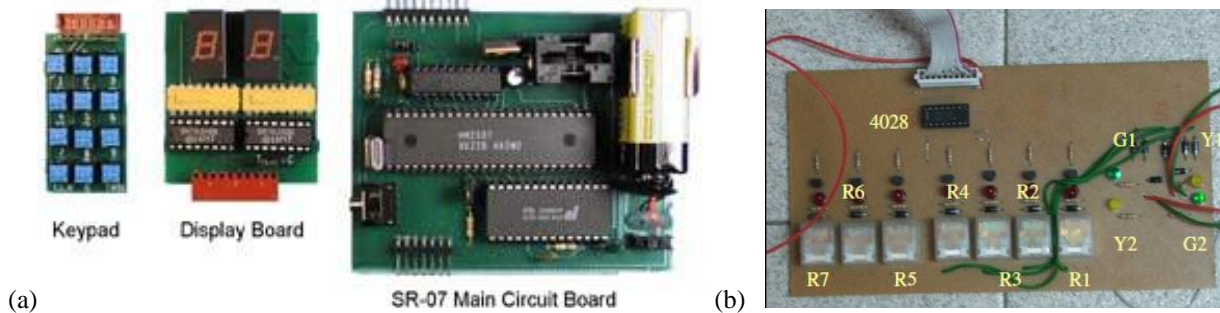

Figure 3: Interfacing Electronic circuit system



(a)

SR-07 Main Circuit Board

(b)



(c)



(d)



(e)

Figure 4 (a) Voice recognition circuit (b) Interfacing circuit (c) Speed control circuit to control motor (d) Mechanical and Electrical design of the wheel chair (e) Hardware design of wheel chair with the interfacing circuits

The interfacing electronic circuit, Fig.4 (b) is used to connect the voice recognition circuit, Fig.4 (a) and speed control circuit Fig.4(c). The directions of motor are indicated by four LEDs on the interfacing circuit. In Fig 4 (d), with the combination of these mechanical and electrical parts, the wheelchair is designed manually. The manual wheelchair has been designed to be an electrical wheelchair with the interfacing circuits. The electrical powered wheelchair uses a wheelchair motor which was specially designed for the purpose to move the wheelchair with a load. The wheelchair motors normally have high torque and high revolution per minutes (rpm). These criteria will make sure that the electrical wheelchair can move smoothly when it is being used. The fig 4 (e) shows the hardware design of the wheel chair with the required interfacing circuits.

### 2.3 Voice controlled principle of the wheel chair

In this paper some advanced voice commands are designed so that the user can choose the speed. The user can select the speed in two levels, either slow or fast speed to move. For example if the user need only to move in a short distance or to approach object, he should use the slow speed. This speed selection is important for safety and extra manoeuvrability of the user. The main part of the design is to control the motion of the wheelchair. Fig. 5 shows the working principle of the wheel chair based on the voice recognition. There are four types of motions considered, moving forward, moving in reverse direction, moving to the left and moving to the right. For the speed, the user may use slow or fast speed. Slow speed is important as the user want to move in short distance or approaching an object. The system starts by



applying the supply voltage to the speech recognition circuit. The system will be in stand by condition in which the LED on circuit recognition board will be turned on.

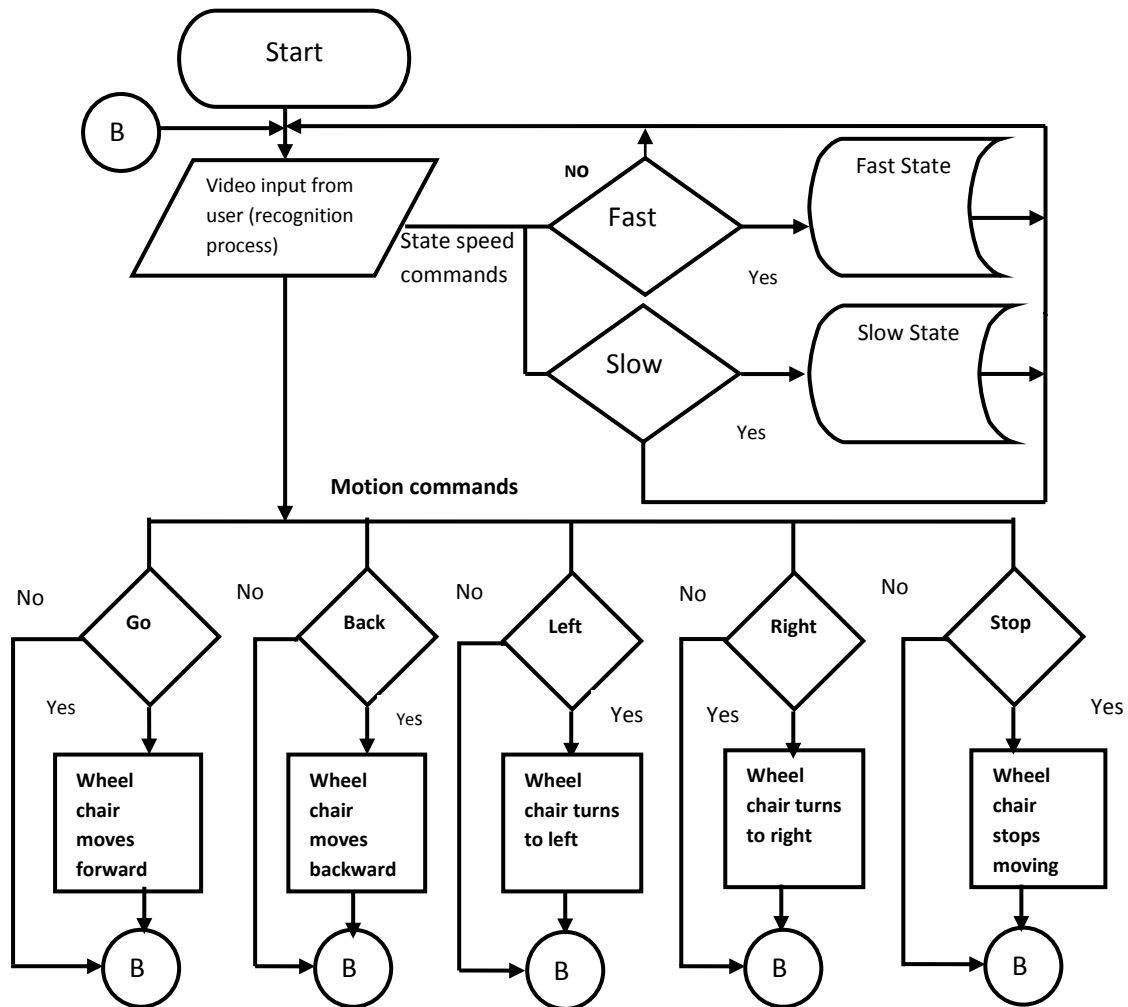

Figure 5 Voice controlled motion of the wheelchair

The system can be controlled in two speed conditions, fast and slow. For fast condition the system will supply higher current to the motors. If the user does not want the wheelchair to move in high speed, the slow speed can be set by applying low current supply to the motors. The direction and speed of the wheelchair depends on the user. For the forward command the wheelchair moves in forward direction. For the reverse direction the opposite movement of wheel rotation will occur. The left command will make right wheel moves forward and left wheel moves backward. The right command makes left wheel moves forward and right wheel rotate backward. In this system, by assigning the word command stop the rotation of both motors will stop. The wheelchair system will go back to the stand by condition or end the whole system by turning off the power supply of the speech recognition board. The voice commands used are as per Table 1. This processor is the best choice as it is easy to build programmable speech recognition circuit. The circuit is programmed in such a way that we train the words (or vocal utterances) that we want the circuit to recognize. This kit allows us to experiment with many facets of speech recognition technology. Unlike software based speech recognition systems like Dragon naturally speaking (tm) and Via Voice (tm), it is stand alone circuit and works without a personal computer. To train the voice control circuit, the keypad containing 12 switches is used. In this design the memory used is trained to recognize the voice as per the conditions in Table 1.

Table 1: Voice commands with binary values

Voice	Conditions	Digital display	Voice	Binary commands
FORWARD	Moves straight to the forward	01	FAST	0001
REVERSE	Moves straight to the backward	02	SLOW	0010
ON	Sets the wheelchair on	03	REVERSE	0011
OFF	Sets the wheelchair off	04	FORWARD	0100
LEFT	Turn to left	05	LEFT	0101
RIGHT	Turn to right	06	RIGHT	0110
STOP	Stop the system	07	STOP	0111

ON	Giving supply to wheelchair / home appliances	Switch		
OFF	Switching off the supply	Switch		

Fig. 6 shows the block diagram of the controlling mechanism for home appliances using voice recognition circuit. This system uses the 89c51 microcontroller and it has a flash programmable memory that is programmed using assembly programming to control the home appliances. The user of this wheel chair can operate the home appliances (like light, fan and TV) using their voice commands.

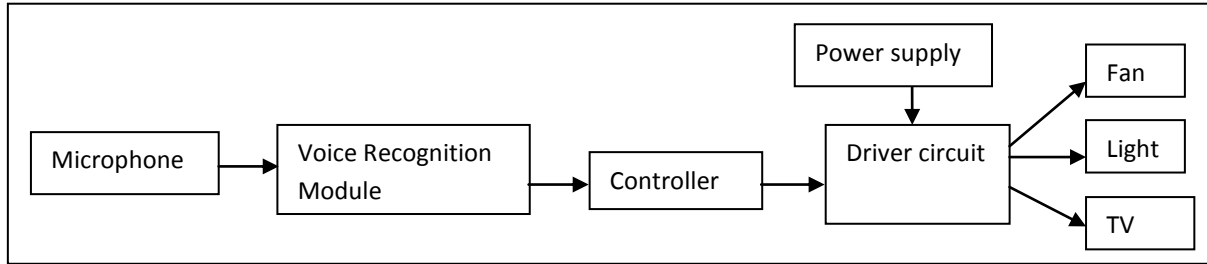

Figure 6 Block diagram of voice controlled home appliances

### III. Results And Discussion

After the design and development of the wheel chair with respective interfacing circuits, the technology was tested for the motion of the wheel chair and home automation using trained voice. This design is experimented based on two important aspects, firstly, on the accuracy of the system and secondly, wheelchair velocity & home automation control by means of on & off control commands. The proposed design was implemented using normal people. This would be implemented for disabled people after having the smoothly furnished design of the wheel chair.

#### 3.1 Accuracy of the Wheel Chair

This experiment was conducted in a room which is in silent condition to observe the result of the experiment. The purpose of the experiment is to find out the accuracy of the wheel chair in response to the speech (voice) in different conditions.

Condition 1: silent area

Five trials of experiments were done with the new design based on the commands listed at the Table 1. From Table 2, there are 4 over 5 commands were recognized by the speech recognition circuit to move the wheel chair. The percentage of the accuracy of the wheel chair in silent condition is 80% (Accuracy = 4/5 X100%= 80%).

Voice commands	(a) Result in silent area						(b) Result in noisy condition					
	Experiment trials					Total Response	Experiment trials					Total Response
	1	2	3	4	5		1	2	3	4	5	
On(HA)	1	1	0	1	1	4	0	1	1	1	0	3
OFF(HA)	1	1	1	1	0	4	0	0	1	1	0	2
Reverse	1	1	1	1	1	5	1	1	1	1	0	4
Forward	1	0	1	1	1	4	1	1	1	0	0	3
Right	1	1	0	1	1	4	1	1	0	0	0	2
Left	1	1	1	1	1	5	1	1	0	1	0	3
Stop	1	0	1	1	1	4	0	1	1	0	1	3

Table 2(a): Result in silent area; (b) Result in Noisy condition (HA-Home Appliances)

Condition 2: noisy area

The testing is done outside the silent room where it is considered as natural environment. From this experiment, the results are obtained as per the Table 2(b). From the table, there are 3 over 5 commands recognized by the trained speech recognition circuit. The percentage of the accuracy of speechRecognition circuit in noisy condition is 60%. This is calculated as, Accuracy = 3/5 X100 = 60%.

From Fig. 7, it is observed that the accuracy of the voice recognition circuit in silent condition is less compared to that in the noisy condition.

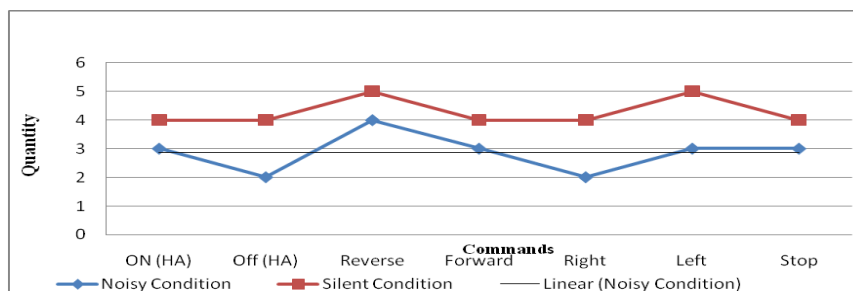

Figure 7 Graph of accuracy of the voice recognition circuit in two conditions

### 3.2 Velocity

The important aspect of the wheelchair system is to find its velocity. While the Voice controlled wheelchair moving in a straight line, the distance and time were noted for velocity. The velocity of the wheel chair needs to be experimented under two conditions. First the velocity is observed in unloaded condition. The wheelchair was made to move in a straight line and the result was observed. The distance measured was 6 meters and time is 6.34s. So, distance over time is 0.95m/s. Second, a person weighing around 20kg to 25kg was seated at the wheelchair. The voice controlled wheelchair was allowed to move in a straight line. Now the distance measured was 4 meters and time is 5.44s. So the velocity of the wheel chair with load is 0.74m/s. Based on the above result, the velocity of voice controlled wheelchair is affected by the load. It is observed that the velocity of the wheelchair system will decrease proportional to the load that is carried by the system.

## IV. Conclusion

This proposed system contributes to the self dependency of physically challenged and older people. It reduces the manual effort for acquiring and distinguishing the command for controlling the motion of a wheelchair & home appliances. The speed and direction of the wheelchair now can be selected using the specified commands. Thus the only thing needed to ride the wheelchair is to have a trained voice. Besides that, the development of this project is done with less cost and affordable. However this system requires some improvements to make it more reliable. This design could be improved by implementing wireless communication in the wheel chair. By improving this system, we directly enhance the life style of the disabled people in the community. Lastly, we hope that this kind of system could contribute to the evolution of the wheelchair technology.

## REFERENCES

- [1] Linda Fehr, MS, W. Edwin, *et al.*, Adequacy of power wheelchair control interfaces for persons with severe disabilities: A clinical survey, *Journal of Rehabilitation Research and Development*, 37(3), 2000, 353-360.
- [2] Simpson RC, Levine SP, Voice control of a powered wheelchair, *IEEE Trans Neural System Rehabilitation Eng.* 2000, 122-125.
- [3] X. S. Li, *et al.*, Analysis and Simplification of Three-Dimensional Space Vector PWM for Three-Phase Four-Leg Inverters, *IEEE Trans. on Industrial Electronics*, vol 58, 2011, 450-464.
- [4] R. Cooper, M. Boninger, *et al.*, Engineering better wheelchairs to enhance community participation, *IEEE Trans. Neural Systems Rehabilitation Eng.* 14(4), 2006, 438-455.
- [5] C.Chandramouli and Vivek Agarwal, Speech Recognition based Computer Keyboard Replacement for the Quadriplegics, Paraplegics, Paralytics and Amputees, ACM publishers, *IEEE International Workshop on Medical Measurements and Applications*, 2009, 241-245.
- [6] Kailash Pati Dutta, *et al.*, Microcontroller Based Voice Activated Wireless Automation System, *VSRD-IJEECE*, 2 (8), 2012, 642-649.
- [7] Thomas Rofer, Christian Mandel and Tim Laue, Controlling an Automated Wheelchair via Joystick/Head-Joystick Supported by Smart Driving Assistance, *IEEE 11th International Conference on Rehabilitation Robotics*, 2009, 743-748.
- [8] Ha, T.H. Tran and G. Dissanayake, A wavelet- and neural network-based voice interface system for wheelchair control, *Int. J. Intelligent Systems Technologies and Applications*, 1(2), 2005, 49-65.
- [9] Tom Carlson and Yiannis Demiris, Collaborative Control for a Robotic Wheelchair: Evaluation of Performance, Attention and Workload, *IEEE Trans. on systems, man, and cybernetics: part b*, 2011, 1-12.

## BIBLIOGRAPHY OF AUTHORS

R.Puviarasi	She is working as an Assistant Professor in Saveetha University, Chennai, India. She is graduated from Anna University, Coimbatore with M.E in Embedded & Control Systems and B.E in Electrical & Electronics Engineering from Anna University, Chennai. Her research areas are Embedded systems, Renewable energy-solar and wind power systems, machines and control systems
Mritha Ramalingam	With ten years of teaching experience, she is currently working as a Lecturer in the Faculty of Engineering & Computer Technology, School of Engineering, AIMST University. She is graduated from ANNA University, Chennai with M.E Computer Science & Engineering(CSE) and B.E in CSE from University of Madras, Chennai. She worked as an Assistant Professor under Anna University, Chennai, India. Her research areas are embedded systems, network security, video steganography, computer networks and wireless networks
Elanchezhian Chinnavan	With fifteen years of teaching and clinical experience, he is currently working as a Lecturer in School of Physiotherapy, AIMST University. He worked as an Assistant Professor in Meenakshi University, Chennai, India. He worked as physiotherapist in many hospital organizations and in mentally retarded rehabilitation centers. He is specialized in Neurology.