

# STATCOM for Improved Dynamic Performance of Wind Farms in Power Grid

Mohammad Ilyas<sup>1</sup>, Mohammad Ubaid Soherwardi<sup>2</sup>

<sup>1,2</sup>(Department of Electrical and Electronics Engineering, Al-Falah School of Engineering and Technology, Faridabad (Haryana))

**Abstract:** Application of FACTS controller called Static Synchronous Compensator STATCOM to improve the performance of power grid with Wind Farms is investigated. The essential feature of the STATCOM is that it has the ability to absorb or inject the reactive power with power grid. Therefore, the voltage regulation of the power grid with STATCOM FACTS device is achieved. Moreover restoring the stability of the power system having wind farm after occurring severe disturbance such as faults or wind farm mechanical power variation is obtained with STATCOM controller. The dynamic model of the power system having wind farm controlled by proposed STATCOM is developed. To validate the powerful of the STATCOM FACTS controller, the studied power system is simulated and subjected to different severe disturbances. The results prove the effectiveness of the proposed STATCOM controller in terms of fast damping the power system oscillations and restoring the power system stability.

**Keywords:** STATCOM, Wind Generation, Transient Stability.

## I. Introduction

Now a days wind as a significant proportion of non pollutant energy generation is widely used. If a large wind farm, which electrically is far away from its connection point to power system, is not fed by adequate reactive power, it present major instability problem. Various methods to analyze and improve wind farm stability have been performed. The stability of wind driven self excited induction generator SEIG s is analyzed. A breaking resistor to absorb active power during fault to enhance the system stability is developed. Flexible AC transmission system FACTS devices such as Static Synchronous Compensator STATCOM to improve the stability in wind farm is studied.

As a consequence, it will become necessary to require wind farms to maintain continuous operation during grid disturbances and thereby support the network voltage and frequency. In addition, in the area of a deregulated electricity industry, the policy of open access to transmission systems, which helped create competitive electricity markets, led to a huge increase in energy transactions over the grid and possible congestion in transmission systems[1]. The expansion of power transfer capability of transmission systems has been a major problem over the past two decades. Under these conditions, the modern power system has had to confront some major operating problems, such as voltage regulation, power flow control, transient stability, and damping of power oscillations, etc. FACTS devices can be a solution to these problems.

They are able to provide rapid active and reactive power compensations to power systems, and therefore can be used to provide voltage support and power flow control, increase transient stability and improve power oscillation damping. Suitably located FACTS devices allow more efficient utilization of existing transmission networks. The STATCOM is used to provide rapid and fast control of voltage during during steady state and transient stability. This issue is even more critical in the case of microgrids, since certain FACTS controllers, particularly STATCOMs, are being considered as a possible solution for some of the voltage and angle stability problems inherent to these power grids. Consequently, typical STATCOM models are validated here using system identification techniques to extract the relevant electromechanical mode information from time-domain signals. System identification techniques are used to readily and directly compare fairly distinct STATCOM models, thus avoiding matrix based eigenvalue studies of complex system models and/or modeling approximations.

In this paper, a STATCOM is added to the power network to provide dynamic voltage control for the wind farm, dynamic power flow control for the transmission lines, relieve transmission congestion and improve power oscillation damping. Simulation results show that the STATCOM devices significantly improve the performance of the wind farm and the power network during transient disturbances.

## II. Wind Farm And Electric Generator Model

A wind turbine is a device that converts kinetic energy from the wind into electrical power. Wind turbine use squirrel cage induction generator output power to its nominal value for high wind speeds. In order to generate power the induction speed must be slightly above the synchronous speed but the speed variation is typically so small that the WTIG is considered to be a fixed-speed wind generator.

A wind turbine used for charging batteries may be referred to as a wind charger [2]. The result of over a millennium of windmill development and modern engineering, today's wind turbines are manufactured in a wide range of vertical and horizontal axis types. The smallest turbines are used for applications such as battery charging for auxiliary power for boats or caravans or to power traffic warning signs. Slightly larger turbines can be used for making small contributions to a domestic power supply whilst selling unused power back to the utility supplier via the electrical grid. Arrays of large turbines, known as wind farms, are becoming an increasingly important source of renewable energy and are used by many countries as part of a strategy to reduce their reliance on fossil fuels. Unlike the trend toward large-scale grid connected wind turbines seen in the West, the more immediate demand for rural energy supply in developing countries is for smaller machines in the 5 - 100 kW range [3]. These can be connected to small, localised micro-grid systems and used in conjunction with diesel generating sets and/or solar photovoltaic systems (see hybrid systems section later in this fact sheet). Currently, the use of wind power for electricity production in developing countries is limited, the main area of growth being for very small battery charging wind turbines (50 - 150 Watts). In Inner Mongolia there are over 30,000 such machines used by herders for providing power for lighting, televisions, radios, etc.

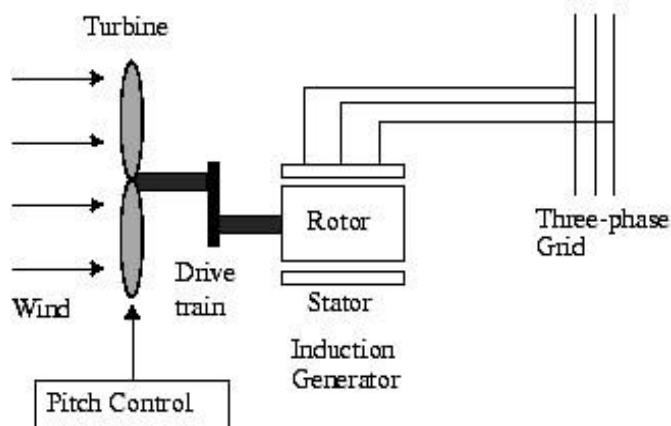

Figure 1: Wind turbine and induction generator

Where you choose to build your wind turbine is important. Remember that if nearby houses, tree lines and silos obstruct the full force of the wind from your wind turbine, you will not be able to generate as much power. Wind speeds tend to be higher on the top of a ridge or hill, and for that reason it is a good idea to locate wind turbines at hilly locations [4]. Just remember to keep your turbine away from high turbulence. Neighbours must also be taken into consideration when picking a spot to build your turbine. The farther your wind turbine site is from neighbouring houses, the better. Do not expect your wind turbine to generate the same amount of power all the time. The wind speed at a single location may vary considerably, and this can have a significant impact on the power production from a wind turbine. Even if the wind speed varies by only 10%, the power production from a wind turbine can vary by up to 25%.

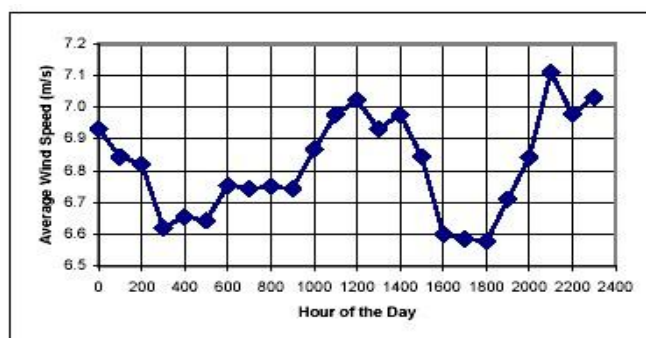

Figure 2: Example of wind speed distribution by hour of the day. Values shown are monthly averages of measurements made by anemometers. (Source: US Department of Energy).

The power available in the wind is proportional to the cube of its speed. This means that if wind speed doubles, the power available to the wind generator increases by a factor of 8 ( $2 \times 2 \times 2 = 8$ ) [7].

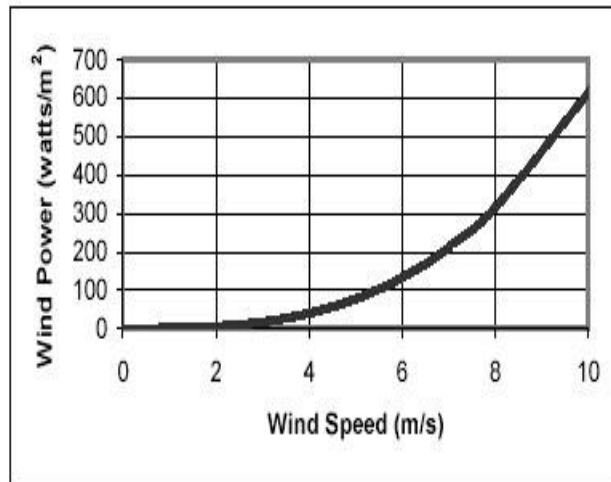

Figure 3: Relationship between wind speed and wind power.

### III. Statcom Model

A static synchronous compensator (STATCOM), also known as a "static synchronous condenser" ("STATCON"), is a regulating device used on alternating current electricity transmission networks. It is based on a power electronics voltage-source converter and can act as either a source or sink of reactive AC power to an electricity network. If connected to a source of power it can also provide active AC power. It is a member of the FACTS family of devices

Usually a STATCOM is installed to support electricity networks that have a poor power factor and often poor voltage regulation. There are however, other uses, the most common use is for voltage stability. A STATCOM is a voltage source converter (VSC)-based device, with the voltage source behind a reactor. The voltage source is created from a DC capacitor and therefore a STATCOM has very little active power capability. However, its active power capability can be increased if a suitable energy storage device is connected across the DC capacitor. The reactive power at the terminals of the STATCOM depends on the amplitude of the voltage source. For example, if the terminal voltage of the VSC is higher than the AC voltage at the point of connection, the STATCOM generates reactive current; on the other hand, when the amplitude of the voltage source is lower than the AC voltage, it absorbs reactive power.

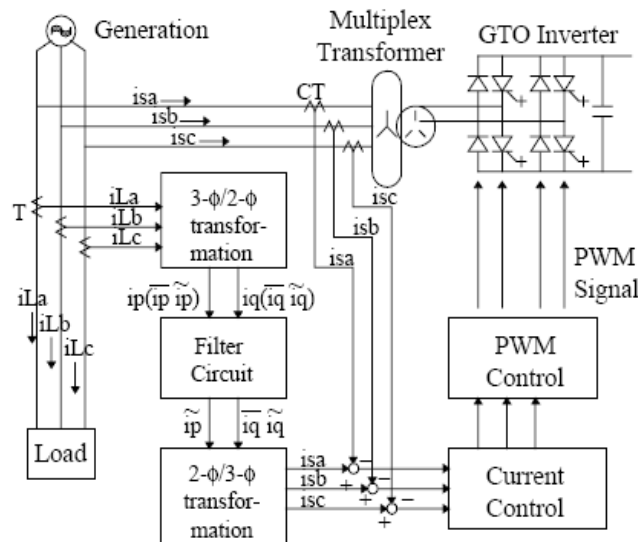

Figure 4: A typical control circuit of the STATCOM

The three-phase load currents to be compensated ( $i_{La}$ ,  $i_{Lb}$ , and  $i_{Lc}$  shown in the last Figure) are measured from the system and transformed to two phase orthogonal components ( $i_p$  and  $i_q$ ) on rotating coordinates synchronized with the line voltage. The outputs of the filter circuit are inversely transformed to

three-phase components ( $i_{sa}$ ,  $i_{sb}$  and  $i_{sc}$  shown in Figure). The output current of the STATCOM is controlled by three-phase current feedback control using  $i_{sa}$ ,  $i_{sb}$ , and  $i_{sc}$  as reference signals for each phase. The output signals of the current control added by a sensed system voltage signal becomes the voltage reference signal of the PWM control. The PWM control circuit generates the firing signal of the GTO by comparing triangular wave carrier signals to the voltage reference signal.

The response time of a STATCOM is shorter than that of an SVC, mainly due to the fast switching times provided by the IGBTs of the voltage source converter. The STATCOM also provides better reactive power support at low AC voltages than an SVC, since the reactive power from a STATCOM decreases linearly with the AC voltage (as the current can be maintained at the rated value even down to low AC voltage). A static VAR compensator (SVC) can also be used for voltage stability. However, a STATCOM has better characteristics than a SVC. When the system voltage drops sufficiently to force the STATCOM output current to its ceiling, its maximum reactive output current will not be affected by the voltage magnitude. Therefore, it exhibits constant current characteristics when the voltage is low under the limit. In contrast the SVC's reactive output is proportional to the square of the voltage magnitude. This makes the provided reactive power decrease rapidly when voltage decreases, thus reducing its stability. In addition, the speed of response of a STATCOM is faster than that of an SVC and the harmonic emission is lower. On the other hand STATCOMs typically exhibit higher losses and may be more expensive than SVCs, so the (older) SVC technology is still widespread.

#### IV. Modelling

A wind farm consisting of six 1.5-MW wind turbines is connected to a 25-kV distribution system exports power to a 120-kV grid through a 25-km 25-kV feeder. The 9-MW wind farm is simulated by three pairs of 1.5 MW wind-turbines. Wind turbines use squirrel-cage induction generators (IG). The stator winding is connected directly to the 60 Hz grid and the rotor is driven by a variable-pitch wind turbine. The pitch angle is controlled in order to limit the generator output power at its nominal value for winds exceeding the nominal speed (9 m/s).

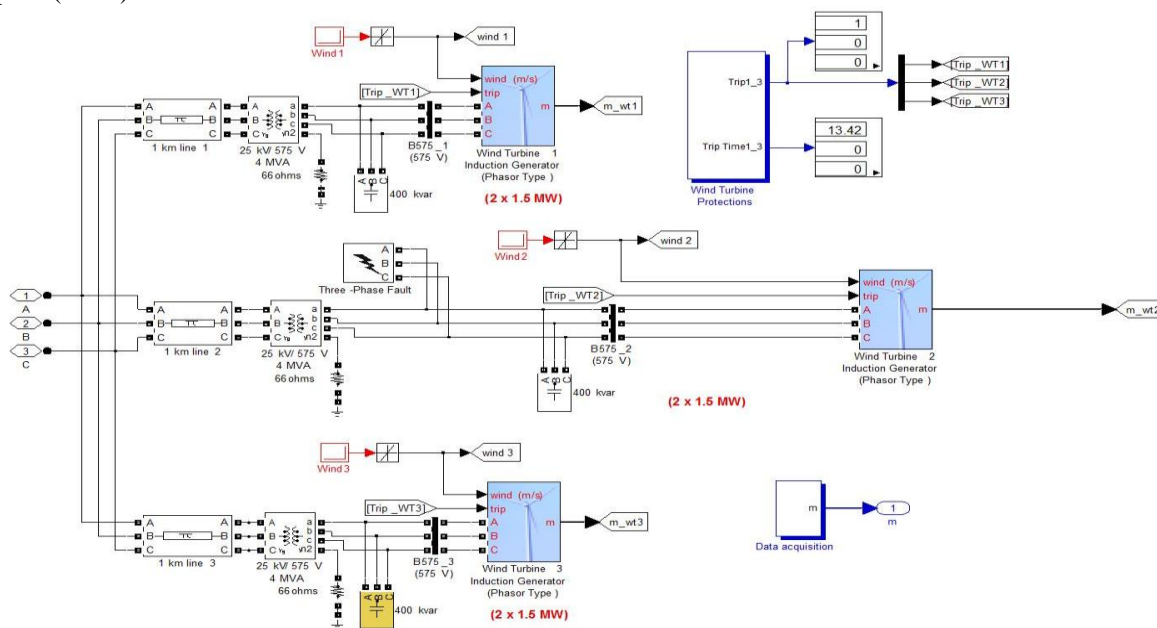

Fig 5. Wind farm consisting of 6 wind turbine induction generator

In order to generate power the IG speed must be slightly above the synchronous speed. Speed varies approximately between 1 Pu at no load and 1.005 Pu at full load. Each wind turbine has a protection system monitoring voltage, current and machine speed. Reactive power absorbed by the IGs is partly compensated by capacitor banks connected at each wind turbine low voltage bus (400 kvar for each pair of 1.5 MW turbine). The wind speed applied to each turbine is controlled by the "Wind 1" to "Wind 3" blocks. Initially, wind speed is set at 8 m/s, then starting at  $t=2s$  for "Wind turbine 1", wind speed is rammed to 11 m/s in 3 seconds. The same gust of wind is applied to Turbine 2 and Turbine 3, respectively with 2 seconds and 4 seconds delays. Then, at  $t=15 s$  a temporary fault is applied at the low voltage terminals (575 V) of "Wind Turbine 2". Start simulation and observe the signals on the "Wind Turbines" scope monitoring active and reactive power, generator speed, wind speed and pitch angle for each turbine.

From the Fig.6 it is clear that to keep the voltage close to 1 Pu, the STATCOM installed in the system provides 3 Mvar. So this amount of reactive power supplied by the STATCOM keeps the voltage constant irrespective of changes in the wind speed which otherwise is not possible if wind system is directly connected to the grid. So it is important to keep the voltage constant in the distribution system, hence voltage regulation is required in the distribution network. Voltage Source Converter (VSC) based STATCOM achieves voltage regulation in the connected bus by absorbing/supplying the required reactive power. For each pair of turbine the generated active power starts increasing smoothly (together with the wind speed) to reach its rated value of 3 MW in approximately 8s. Over that time frame the turbine speed will have increased from 1.0028 Pu to 1.0047 Pu. Initially, the pitch angle of the turbine blades is zero degree. When the output power exceed 3 MW, the pitch angle is increased from 0 deg to 8 deg in order to bring output power back to its nominal value. Observe that the absorbed reactive power increases as the generated active power increases. At nominal power, each pair of wind turbine absorbs 1.47 Mvar. For 11m/s wind speed, the total exported power measured at the B25 bus is 9 MW and the STATCOM maintains voltage at 0.984 Pu by generating 1.62 Mvar (see "B25 Bus" and "Statcom" scopes).

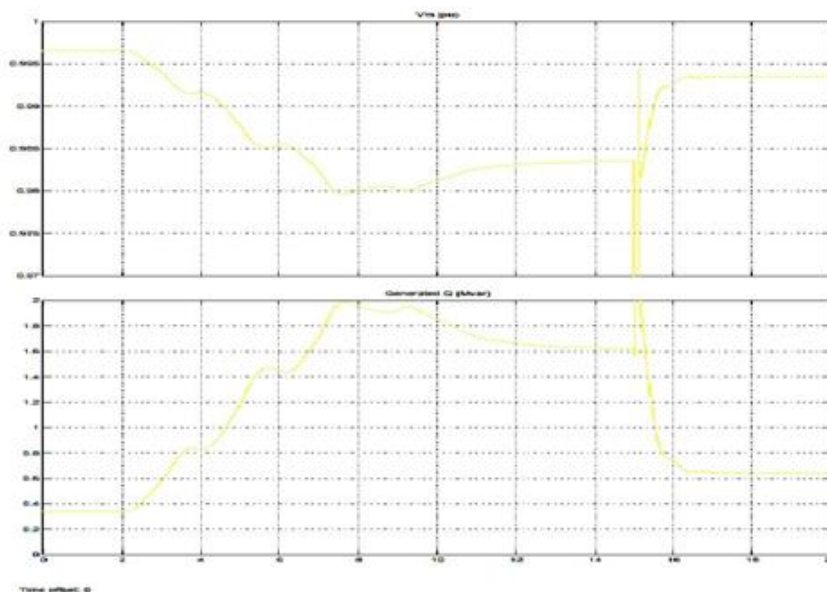

Figure 6: Reactive power and voltage at STATCOM terminals

At t=15 s, a phase to phase fault is applied at wind turbine 2 terminals, causing the turbine to trip at t=15.11 s. If you look inside the "Wind Turbine Protections" block you will see that the trip has been initiated by the AC Under-voltage protection. After turbine 2 has tripped, turbines 1 and 3 continue to generate 3 MW each.

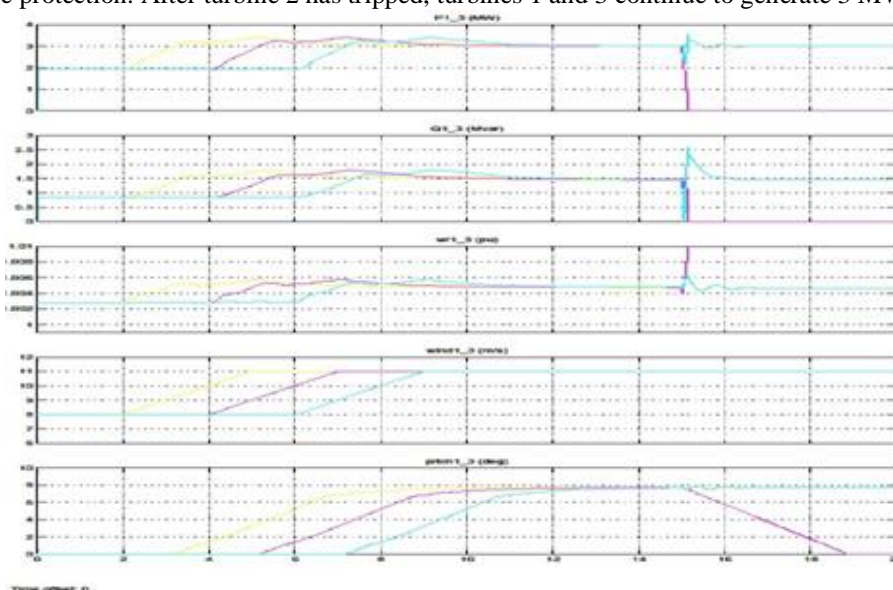

Figure7: Phase to phase fault

#### 4.1 WITH STATCOM

The rest of reactive power required to maintain the 25-kV voltage at bus B25 close to 1 Pu is provided by a 3-Mvar STATCOM with a 3% droop setting. Open the "Wind Farm" block and look at "Wind Turbine 1". Open the turbine menu and look at the two sets of parameters specified for the turbine and the generator. Each wind turbine block represents two 1.5 MW turbines. Open the turbine menu, select "Turbine data" and check "Display wind-turbine power characteristics". The turbine mechanical power as function of turbine speed is displayed for wind speeds ranging from 4 m/s to 10 m/s. The nominal wind speed yielding the nominal mechanical power (1pu=3 MW) is 9 m/s. The wind turbine model (from the DR library) and the Statcom model (from the FACTS library) are phasor models that allow transient stability type studies with long simulation times. In this demo, the system is observed during 20 s.

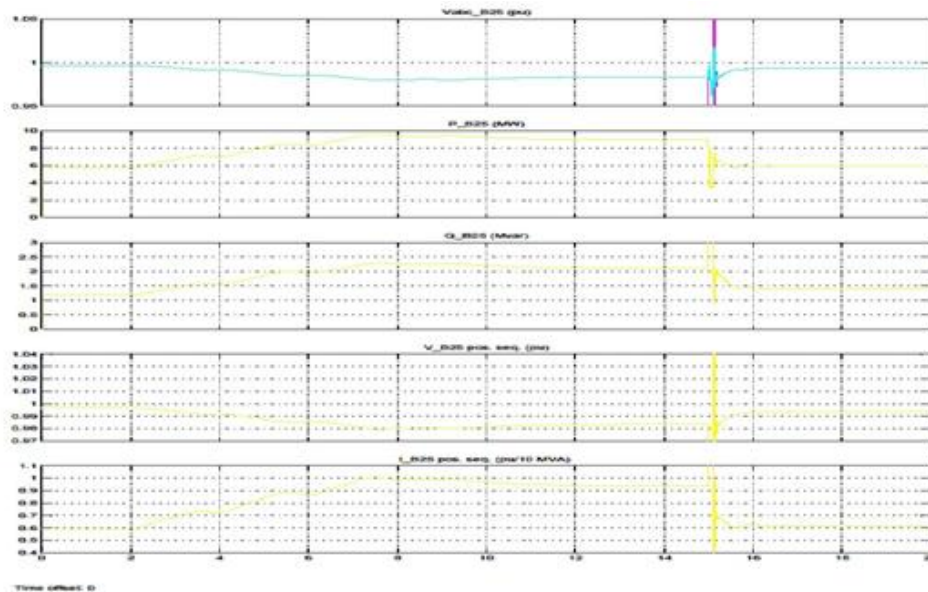

Figure8: Waveforms of different quantities with STATCOM

#### 4.2 WITHOUT STATCOM

Observe on " B25 Bus" scope that because of the lack of reactive power support, the voltage at bus "B25" now drops to 0.91pu[Fig.10]. This low voltage condition results in an over load of the IG of "Wind Turbine 1". "Wind Turbine 1" is tripped at t=13.43 s. If you look inside the "Wind Turbine Protections" block you will see that the trip has been initiated by the AC Over current protection.

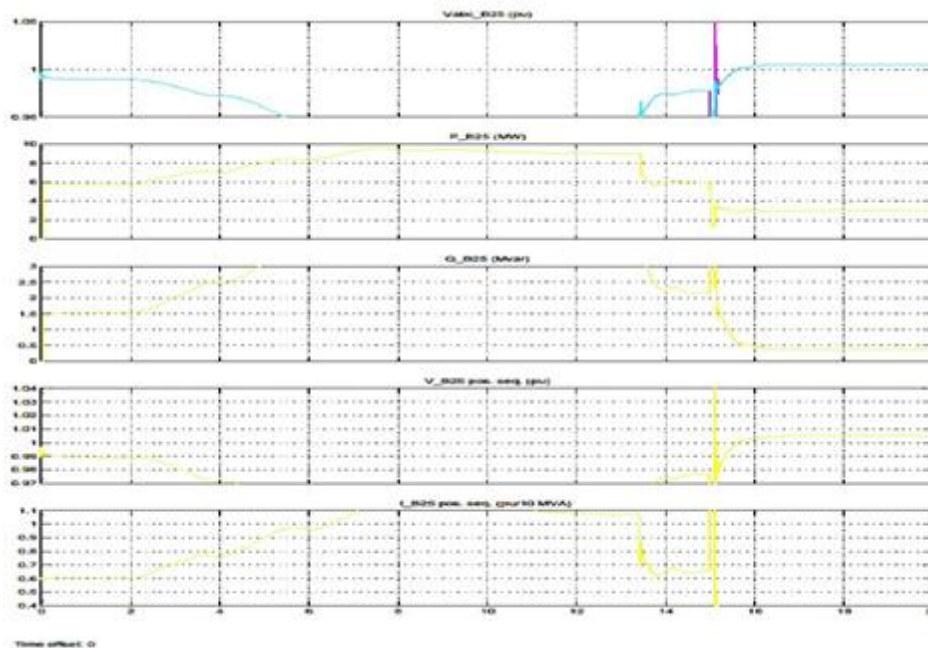

Figure9: Waveforms of different quantities without STATCOM

## V. CONCLUSION

Power system with wind farms performance can be improved using FACTS devices such as STATCOM. The dynamic model of the studied power system is simulated using Simulink Matlab package software. To validate the effect of the STATCOM controller of power system operation, the system is subjected to different disturbances such as faults and power operating conditions. The digital results prove the powerful of the proposed STATCOM controller in terms of Stability improvement, power swings damping, voltage regulation, and increase of power transmission and chiefly as a supplier of controllable reactive power to accelerate voltage recovery after fault occurrence.

## REFERENCES

- [1] V. Akhmatov, Knudsen, A.H. Nielsen, J.K.pedersen, and N.K. poulsen,"A dynamic stability limit of grid connected induction generators", Pro.International IASTED conference on power and energy systems,marbella, spain, 2000.
- [2] L. holdsworth, X.G. Wu, J.B. Ekanayake, and N. Jenkins, "Comparison of fixed-speed and doubly-fed induction generator wind turbines during power system disturbances", IEEE proc. C-Gener. Transm. Distrib. , vol.150, no. 3, pp. 343-352, 2003.
- [3] S.M. Bolik, "Grid requirments challenges for wind turbines", Fourth International Workshop on large-scale Integration of Wind Power and transmission networks for Offshore Wind Farms, Oct .2003.
- [4] L. Holdsworth, N.Jenkins, and G. Strbac, "Electrical stability of large,offshore wind farms", IEEE seventh International Conference on AC-DC power Transmission, pp.156-161-2001.
- [5] Lie Xu Liangzhong Yao Sasse, C.," Comparison of using SVC andSTATCOM for wind farm integration", International Conference on Power System Technology, pp. 1-7, Oct 2006.
- [6] N. G. Hingorani and L. Gyugyi, "Understanding FACTS: Concepts and Technology of Flexible AC Transmission Systems", IEEE, New York,2000, ISBN 0-7803, pp. 3455-3458, 2000.
- [7] EL-Moursi, M.S. and Sharaf,A.M, "Novel STATCOM controllers for voltage stablization of wind energy scheme", Int. J. Global Energy Issues,vol. 26, 2006.
- [8] F.G.R. de campos and A.A. Jr. penteado, "Wind Energy generation Simulation with asynchronous generator connected to ENERSUL distribution System", IEEE/PES Transmission and Distribution conference and Exposition, Latin America, pp. 149-154, 2004.
- [9] Siegfried Heier, "Grid integration of wind energy conversion systems", Jon Wiley & Sons Ltd, 1998.
- [10] E. Uzunovic, "Transient Stability and Power Flow Models of VSC FACTS controllers," Ph.D. dissertation, University of Waterloo,Waterloo, ON, Canada, 2001.
- [11] N. Mithulananthan, C. A. Canizares, J. Reeve, and G. J. Rogers,"Comparison of PSS, SVC and STATCOM controllers for dampingpower system oscillations", IEEE Trans. Power Systems, vol. 18, no. 2,pp. 786-792, May 2003.