

Transient Stability Assessment and Enhancement in Power System

Aysha P. A¹, Anna Baby²

^{1,2} Department of Electrical and Electronics, ASIET Kalady, India

Abstract: Power system is subjected to sudden changes in load levels. Stability is an important concept which determines the stable operation of power system. For the improvement of transient stability the general methods adopted are fast acting exciters, circuit breakers and reduction in system transfer reactance. The modern trend is to employ FACTS devices in the existing system for effective utilization of existing transmission resources. The critical clearing time is a measure to assess transient instability. Using PSAT, the critical clearing time (CCT) corresponding to various faults are calculated. The most critical faults were identified using this calculation. The CCT for the critical faults were found to change with change in operating point. The CCT values are predicted using Artificial Neural Network (ANN) to study the training effects of ANN. TCSC is selected as the FACTS device for transient stability enhancement. Particle Swarm Optimization method is used to find the optimal position of TCSC using the objective function real power loss minimization. The result shows that the technique effectively increases the transient stability of the system.

Keywords: Artificial Neural Network, Critical Clearing Time, Particle Swarm Optimization.

I. INTRODUCTION

Power system networks grow rapidly and continuously with a large number of interconnections. The complicated structure of such network has exposed the system to various contingencies that could lead to system instabilities: steady-state, dynamic or transient. Transient stability analysis is important in evaluating the network's ability to regain an acceptable state of equilibrium after being subjected to either large or small disturbances [1]. The stability characteristic of a power system is analysed from the nature of the set of differential equations when subjected to disturbances [8].

An electric power system is a network of electrical components used to supply, transmit and use power. With the wide access of renewable energy, power system is becoming increasingly complicated, and thus the calculation of transient stability limits is more significant. The development and use of accurate methods to predict the transient stability is crucial in preventing such conditions and therefore of special interest in the field of power system protection and planning. The critical clearing time (CCT) of three-phase fault is an important parameter which shows the transient stability limit of power system. CCT can be used as the indicator to transient stability assessment and artificial neural network is currently a research topic in the field of power system security. The critical faults of a power system can be identified using CCT. Thyristor Controlled Series Capacitor (TCSC) is one of the most effective FACTS devices which are increasingly used nowadays in stressed transmission systems. TCSC can enhance the stability, improve the dynamic characteristics of power system, and increase the transfer capability of the transmission system by reducing the transfer reactance between the buses at which the line is connected. However the effectiveness of TCSCs depends importantly on their locations and sizes in power system. The prediction, identification and avoidance of transient instability points play a significant role in power systems planning and operation.

II. SYSTEM OVERVIEW

Power System Analysis Toolbox (PSAT) was used for the transient stability analysis of the test system. PSAT is an open source Matlab package for analysis and design of small to medium size electric power systems[17]. PSAT includes power flow, continuation power flow, optimal power flow, small-signal stability analysis, and time-domain simulation, as well as several static and dynamic models, including non conventional loads, synchronous and asynchronous machines, regulators, and FACTS. PSAT is also provided with a complete set of user-friendly graphical interfaces and a Simulink-based editor of one-line network diagrams.

For the transient stability study, we consider New England 10-machine 39-bus test system. The single line diagram of the test system is shown in figure below:

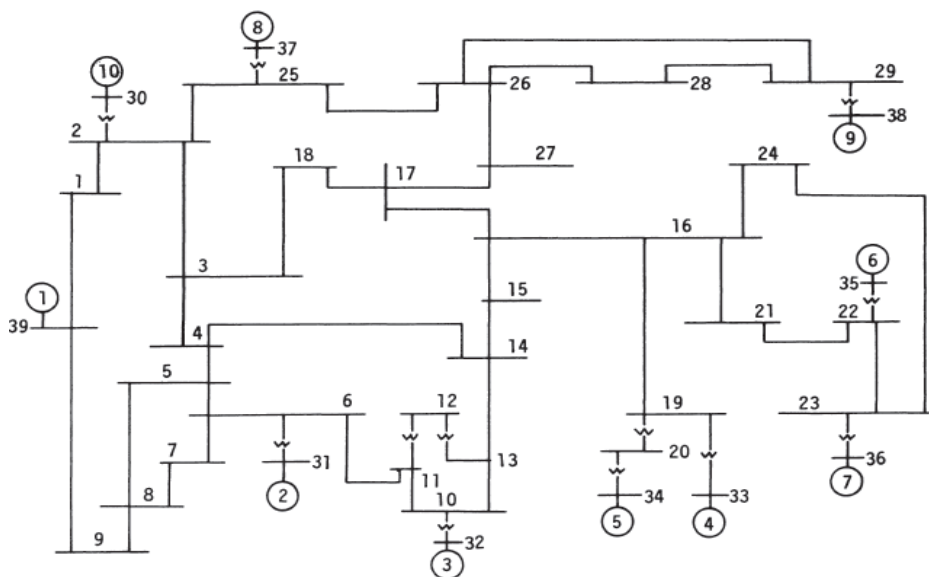

Figure 1: Single line diagram of IEEE 39 bus system

The IEEE 39 Bus (New England) power system is an equivalent power system of subsystems of the New England area and Canada. It consists of 39 Buses of which 10 Buses are generator Buses, 12 transformers, 10 generators, 34 transmission lines, and 19 loads.

Static data for the New England 39 bus test system along with dynamic data for its generators as well as their exciters and AVRs can be found in Ref. [5]. In PSAT, the synchronous machines are initiated after power flow computations. A PV or a slack generator is required to impose the desired voltage and active power at the machine bus. The voltage ratings of all system equipments in kV need to be specified in PSAT.

III. TRANSIENT STABILITY ASSESSMENT

If the relationship between system operating conditions and system stability is reached, by training neural network, the network model should be used to assess online transient stability. For on-line transient stability assessment, CCT is chosen as an accurate indicator of transient stability margin. The fast calculation of CCT is also necessary for on-line stability assessment.

Application of Artificial Neural Network (ANN) to the above-mentioned problem has attained increasing importance mainly due to the efficiency of present day computers. Moreover real-time use of conventional methods in an energy management center can be difficult due to their significant large computational times. One of the main features, which can be attributed to ANN, is its ability to learn nonlinear problem offline with

selective training, which can lead to sufficiently accurate online response. The ability of ANN to understand and properly classify such a problem of highly non-linear relationship has been established in most of the papers and the significant consideration is that once trained effectively ANN can classify new data much faster than it would be possible with analytical model.

The neurons are assumed to be arranged in layers, and the neurons in the same layer behave in the same manner. All the neurons in a layer usually have the same activation function. The neuron in one layer can be connected to neuron in another layer. The arrangement of neurons into layers and the connection pattern within and between layers is known as network architecture. The architecture of a developed network consists of input layer, one hidden layer, and one output layer.

Time domain simulation method is used in this work to assess the transient stability of the power system because it is the most reliable, mature and accurate method compared to other method. The differential equations to be solved in transient stability analysis are non-linear ordinary equations with known initial values.

In this work, the dynamic performance of the system during disturbances is based on observation of the rotor angle of generators via a time domain simulation method. Three-phase faults are created at various locations in the systems at any one time. In this aspect, the power system goes through pre-fault, fault-on, and post-fault stages. When a three-phase fault occurs at any line in the system, a breaker will operate and the respective line will be disconnected at the fault clearing time(FCT) which is set at 10 ms. If the relative rotor angles remain stable after a fault is cleared, it implies that the power system is stable, but, if the relative angles go out of step after a fault is cleared, it means that the system is unstable. The time step for the time domain simulations is set at 0.01 seconds. The time frame of interest in transient stability studies is usually limited to 3 to 5 seconds following the disturbance. It may be extended to 10 seconds for very large systems. All the rotor angles data collected from all the contingencies are then applied to calculate the CCT.

Simulations were carried out using the PSAT software in which the output data were collected and CCT calculated using the MATLAB program.

The generation and load data presented in Ref.[30] was employed as the given initial operating point. Three-phase short-circuit ground fault, the severest fault among the fault types, was applied to each bus in the test systems. All contingencies were cleared by tripping the faulted line, and their CCTs were calculated. There are 46 lines in the system. Each of these lines can be tripped to clear the faults at two buses between which the lines are connected. Hence there are 92 three phase contingency cases in total. Of these 92 cases, there are 22 islanding cases. The islanding cases corresponds to tripping of the lines 2-30, 10-32, 16-19, 19-33, 19-20, 20-34, 22-35, 23-36, 25-37, 29-38 and 6-31.

In the next step, 75 operating points were generated in the vicinity of the given initial operating point by randomly changing +10% to -10% of each generator bus's terminal voltage magnitude and generated active power, +10% to -10% of each load bus's active power demand and reactive power demand. There are nine synchronous machines (one machine act as swing bus) and 17 load buses (two loads connected to generator buses) in the test systems, thus there were $52(9*2 + 17*2)$ input attributes in each case. Output attribute was the CCT corresponding to all three phase faults. The dimension of dataset $75 * 122$ (52 inputs and 70 outputs).

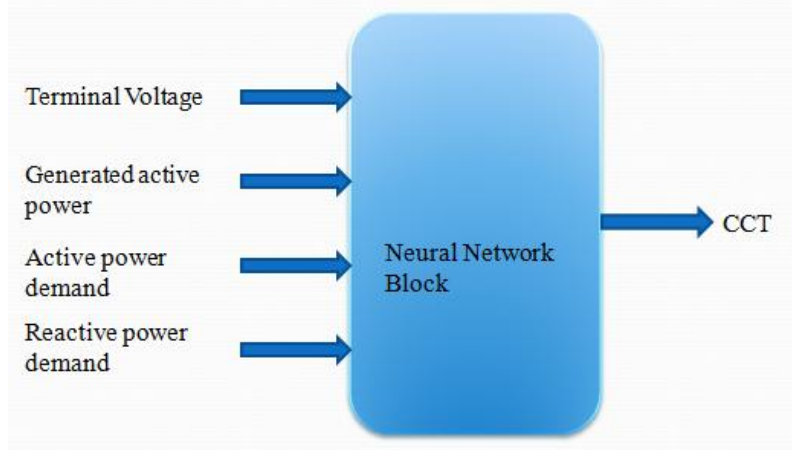

Figure 2: Neural network block diagram

IV. OPTIMAL PLACEMENT OF TCSC USING PSO

To improve the performance of the power system, proper location and parameter setting of FACTS controllers is required. For the optimal utilization and cost of FACTS controllers, optimization can be done based on one of the following without violating the power system constraints:

- a) Reduction in total system real power loss
- b) Increase in Available Transfer Capability

In the last two decades, researchers have been using various algorithms like GA, PSO, HSA for solving the optimal power flow problems and for finding the impact of FACTS on the performance of a power system. Generally in power flow studies, the FACTS devices, such as SVC and TCSC, are usually modelled as controllable impedance and the devices like STATCOM and UPFC are modelled as controllable sources.

PSO is an optimization tool and a population based search procedure in which individuals called particles change their position with time. It was observed that a flock of birds stochastically find food present in an area. Similar to seeking food, the solution to an optimization problem is found out from a solution space with a population based search in which the particles, like birds, change their positions with time.

Inspired initially by flocking birds, Particle Swarm Optimization (PSO) is another form of Evolutionary Computation and is stochastic in nature much like Genetic Algorithms [17]. Instead of a constantly dying and mutating GA population we have a set number of particles that fly through the hyperspace of the problem. A minimization (or maximization) of the problem topology is found both by a particle remembering its own past best position and the entire group's (or flock's, or swarm's) best overall position.

TCSC is the best FACTS device for transient stability improvement. Transient stability assessment in IEEE-39 bus system using Artificial Neural Network shows that the severe faults in the system changes as the operating point varies. So we are positioning the TCSC so as to improve the CCT of these severe faults. The goal of transient stability improvement under contingency condition is to minimize the real power losses by optimal positioning of TCSC and its corresponding parameter.

Objective Function:

$$MinF = \sum_{i=1}^{Ng} P_{gi} - \sum_{j=1}^{Nl} P_{lj}$$

subject to the constraints

Limit of Bus Voltages : $V_{imin} \leq V_i \leq V_{imax}$

Power Flow Limits : $S_{ijmin} \leq S_{ij} \leq S_{ijmax}$

CCT limits : $CCT_i \geq CCT_{imin}$

Particle Swarm Optimisation program is done with the real power loss minimisation as the objective function. The critical CCT values for the first operating point before optimisation is shown:

Tripped line	Faulted bus	CCT
4	2	0.07
4	25	0.07
30	27	0.09
39	25	0.09
39	26	0.05
41	26	0.09
42	26	0.01
42	28	0.01
43	26	0.01
43	29	0.01
44	28	0.01
44	28	0.01

Table 1: CCT values before TCSC placement.

The optimal placement of TCSC is obtained as the following:

$P_{loss} = 0.4431$, TCSC Location = 31, TCSC compensation = 31.0544 %.

The CCT values after placement of TCSC is shown in the table below.

Line	Bus	CCT
4	2	0.17
4	25	0.17
30	27	0.19
39	25	0.19
39	26	0.17
41	26	0.19
42	26	0.11
42	28	0.12
43	26	0.11
43	29	0.12
44	28	0.11
44	28	0.12

Table 2: CCT values after TCSC placement.

After placing TCSC, the CCT values are observed to be greater than 0.1 sec for all the critical contingencies.

V. CONCLUSION

Neural network computation of CCT in the IEEE 39 bus system is done. The most critical faults in a system can be identified using ANN by training it with the previous data. If ANN can be trained using minimum number of inputs this method will be useful for the operators to initiate the necessary control actions to operate the power system with maximum reliability.

It is well established that enhancing the real power supplying ability of a power system is an effective means to improve voltage stability. So schemes for the enhancement of real power is initiated after assessing the critical faults using ANN. Optimal Placement of TCSC for transient stability improvement using PSO is done using P-loss minimization as the objective function for various operating points. The algorithm is easy to implement and is able to find the optimal solution with regard to global best position and size of TCSC. The result seemed to be quite promising when tested on IEEE 39-bus system and can be used in a practical system to find the optimal location of TCSC's for transient stability enhancement.

REFERENCES

- [1] Pavella M, Ernst D, Ruiz-Vega D. "Transient stability of power systems", Kluwer Academic Publishers; 2000.p.6.
- [2] Olwegard A, Walve K, Waglund G, Frank H, Toresng S. "Improvement of transmission capacity by thyristor controlled reactive power", Trans Power Apparatus Syst,VOL.8,NO.10,May 1981.
- [3] Poubek P, Kundur PS, Taylor CW. The anatomy of a power grid black-out, IEEE Power Energy Magazine, Volume 22, Issue 9, Sep 2006 358 ISSN 2278-7763.
- [4] Wehenkel L, Pavella M, Preventive vs. emergency control of power systems, International Conference on Electrical Energy Systems (ICEES 2011), 3-5 Jan 2011.
- [5] Ernst D, Wehenkel L, Pavella M. What is the likely future of real-time transient stability? ,IEEE power energy society power systems conference and exposition, 3-5 Feb 2009.
- [6] Miranda V, Fidalgo JN, Peas Lopes JA, Almeida LB."Real time preventive action for transient stability enhancement with a hybrid neural network optimization approach", IEEE Transactions On Power Systems, VOL. 26,NO.2, February 2011.
- [7] Fidalgo JN, Peas Lopes JA, Miranda V. " Neural network applied to preventive control measures for the dynamic security of isolated power systems with renewable.", IEEE Transactions On Power Systems, VOL. 11,NO.4, 1811-6 ,April 2006.