

Non linear analysis of Robot Gun Support Structure using Equivalent Dynamic Approach

Virkunwar A.K.¹, Addanki Sambasiva Rao.², Patil Vinaay³

^{1,2}Veermata Jijabai Technological Institute, Mumbai, India

³Vaftsya CAE, Pune, India

ABSTRACT: Robot guns are being increasingly employed in automotive manufacturing to replace risky jobs and also to increase productivity. Using a single robot for a single operation proves to be expensive. Hence for cost optimization, multiple guns are mounted on a single robot and multiple operations are performed. Robot Gun structure is an efficient way in which multiple welds can be done simultaneously. However mounting several weld guns on a single structure induces a variety of dynamic loads, especially during movement of the robot arm as it maneuvers to reach the weld locations. The primary idea employed in this paper, is to model those dynamic loads as equivalent G force loads in FEA. This approach will be on the conservative side, and will be saving time and subsequently cost efficient. The approach of the paper is towards creating a standard operating procedure when it comes to analysis of such structures, with emphasis on deploying various technical aspects of FEA such as Non Linear Geometry, Multipoint Constraint Contact Algorithm, Multizone meshing .

Keywords: FEA, Geometric NL, Stress Reduction, Robot Gun Structure, Dynamic forces in Robot arm, Ansys.

I. Introduction

Industrial robots help in increasing efficiency with precision accuracy [1]. Many types of robots are used in automobile industry such as spot welding robot, body painting robot, material handling robot etc [2]. If single robot is used for single operation, it increases accuracy but at the same time it also increases cost. If multiple operations are mounted on a single robot, it will save cost without hampering accuracy. In this paper focus is made on spot welding robot. To mount multiple spot welding guns on single robot a special support structure is needed. In this paper analysis of robot gun support structure is carried out using Ansys workbench v14.0

II. Pre-Processing

Meshing is an integral part of the FEA process as it directly affects the accuracy of the analysis [3]. Mesh generation is one of the most critical aspects of engineering simulation. Too many results in long solver run, and too few may lead to inaccurate results. In ANSYS workbench a new meshing method has been introduced which has been utilized in this paper, it is the Multizone mesh method, which is a patch independent meshing technique, provides automatic decomposition of geometry into mapped regions and free regions. When the Multizone mesh method is selected, all regions are meshed with a pure hexahedral mesh if possible [3]. To handle cases in which a pure hex mesh will not be possible, we can adjust our settings so that a swept mesh will be generated in structured regions and a free mesh will be generated in unstructured regions. Fig. 1 and Fig. 2 shows mesh without Multizone and mesh with Multizone method.

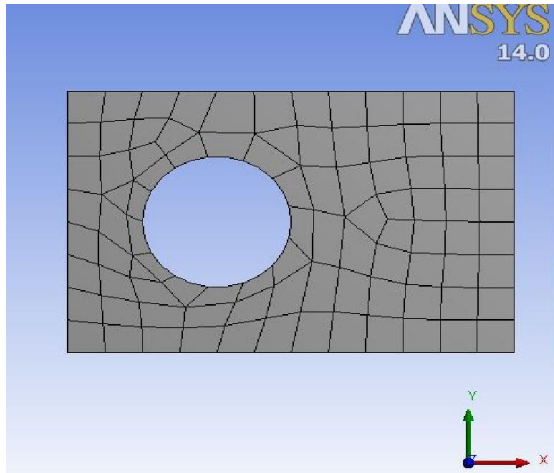

Fig. 1 Mesh without Multizone

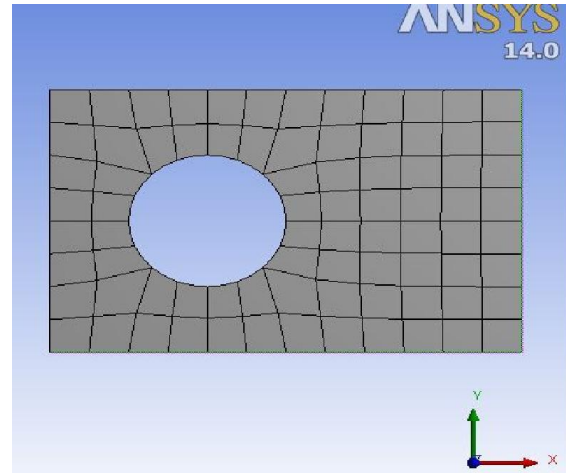

Fig. 2 Mesh with Multizone

Different Meshing methods are selected due to variation in size & shape of the bar. Mesh Method which is used in various bars is as follows:-

Table 1: Various Mesh Method Used

TYPE	Mesh Method
Upper inclined bars	Hex Dominant Method
Vertical bars	Multizone Method
Base Long bar	Hex Dominant Method
Horizontal bars	Multizone Method
Slant bars	Multizone Method
Circular plates	Multizone Method
Welds	Multizone Method

III. Meshed Support Structure

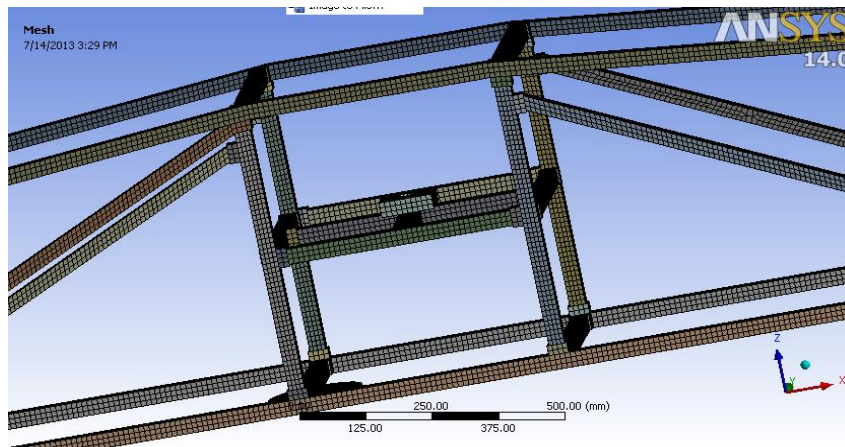

Multi-point constraints (MPCs) are an advanced feature where you connect different nodes and degrees of freedom together in the analysis [4]. They are often used to simulate a boundary condition effect when regular boundary conditions do not provide the correct behavior. Contact model used is bonded contact. These contacts are used when there is a weld contact between two surfaces. Fig. 3 shows the contact regions of the geometry. Mass element used is Mass 21, Fig. 4 shows the point mass attached to the geometry. This mass element replaces the robot guns, reducing model size, and hence solution times are optimal.

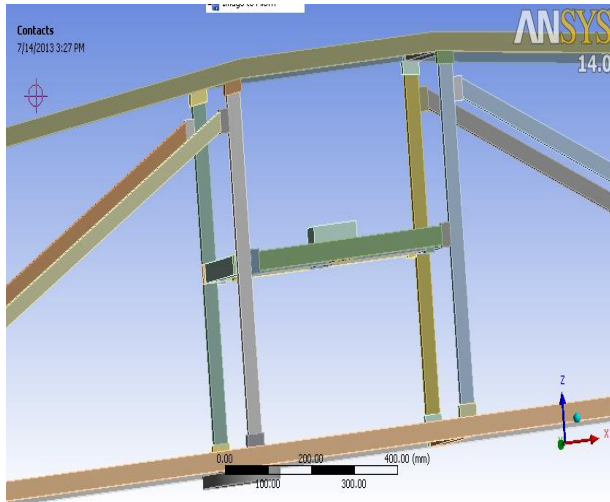

Fig.3. weld contacts

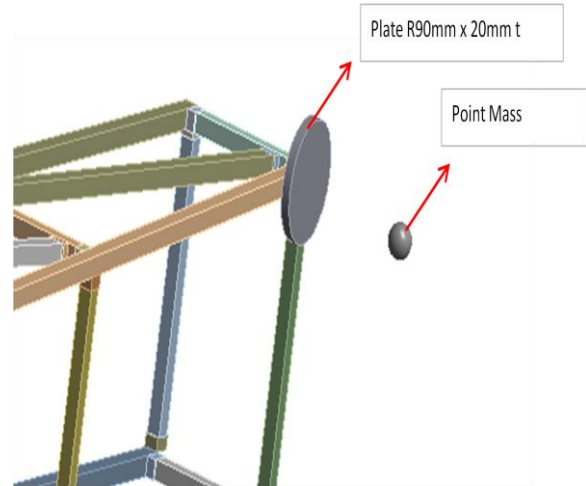

Fig.4. Point mass placed at Circular plates

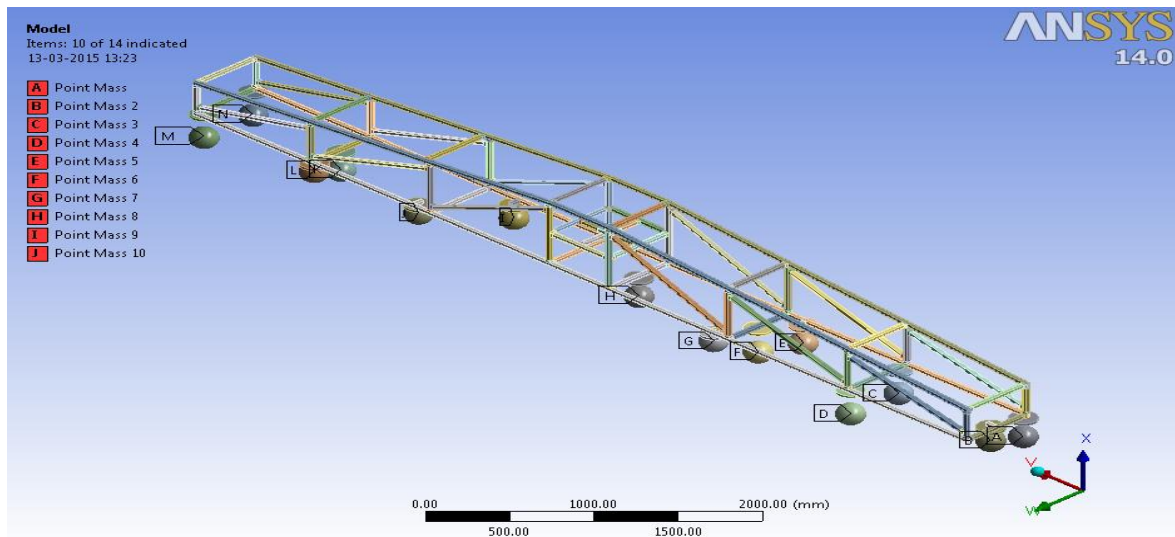

Fig.5. Full view of Point mass attached to support structure

Loads

G-force is a physical force equivalent to one unit of gravity that is multiplied during rapid changes of direction or velocity [5]. Drivers experience severe *G*-forces as they corner, accelerate and brake. *G* force is a measurement of an object's acceleration expressed in *g*-s [6]. It is proportional to the reaction force that an object experiences as a result of this acceleration or, more correctly, as a result of the net effect of this acceleration and the acceleration imparted by natural gravity [7, 8]. *G*-force is not an absolute measurement of force. Analysis of *g*-forces are important in a variety of scientific and engineering fields, especially planetary science, astrophysics, rocket science, and the engineering of various machines such as fighter jets, race cars, spot welding robots and large engines. Basically we can say that *G*-force is used in areas where there is rapid movement of components in a gravity field [9]. Fig. 6, 7, 8 & 9 shows the position of gravitational forces applied in Y and Z directions respectively. The support structure is attached to robot arm. Fig.10 shows the location of fixed support.

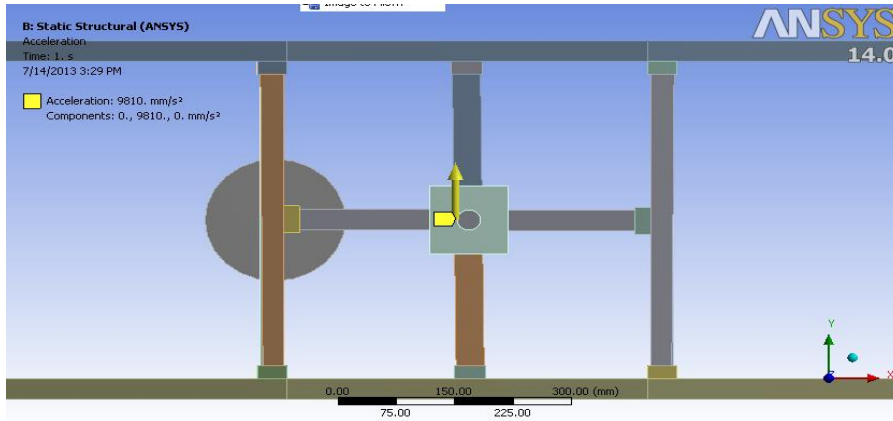

Fig.6. Acceleration applied in Positive Y-direction (1g)

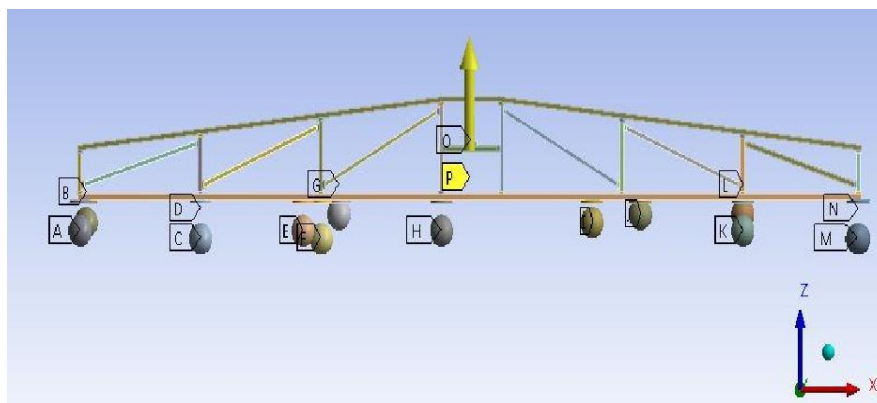

Fig.7. Acceleration applied in Positive Z-direction (1.5g)

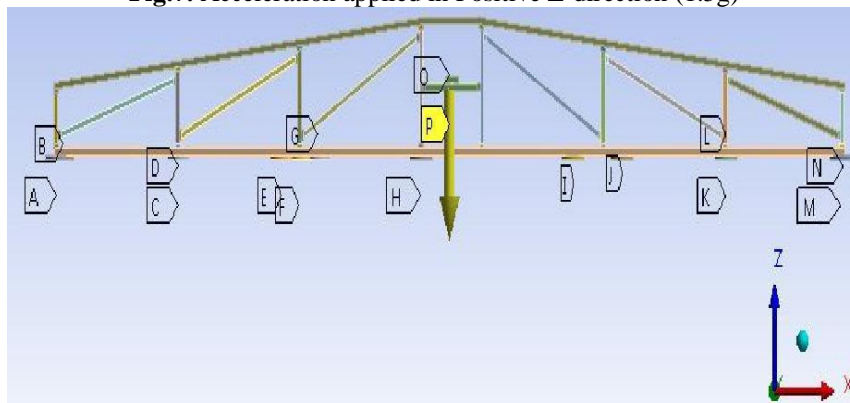

Fig.8. Acceleration applied in Negative Z-direction (2g)

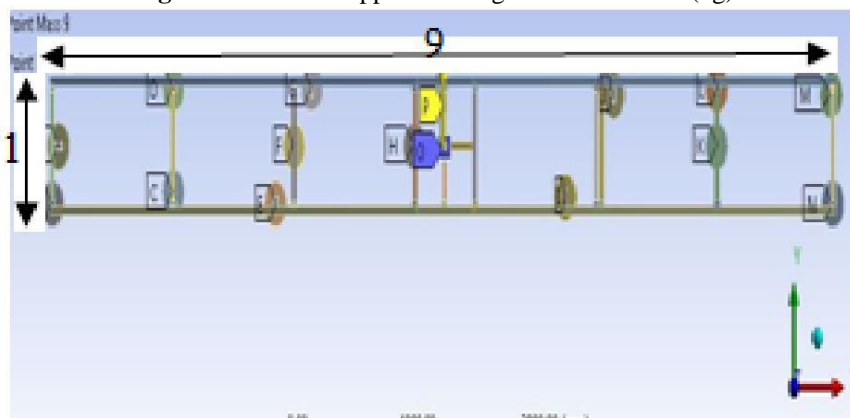

Fig.9. Acceleration applied in Negative Y-direction (1.5g)

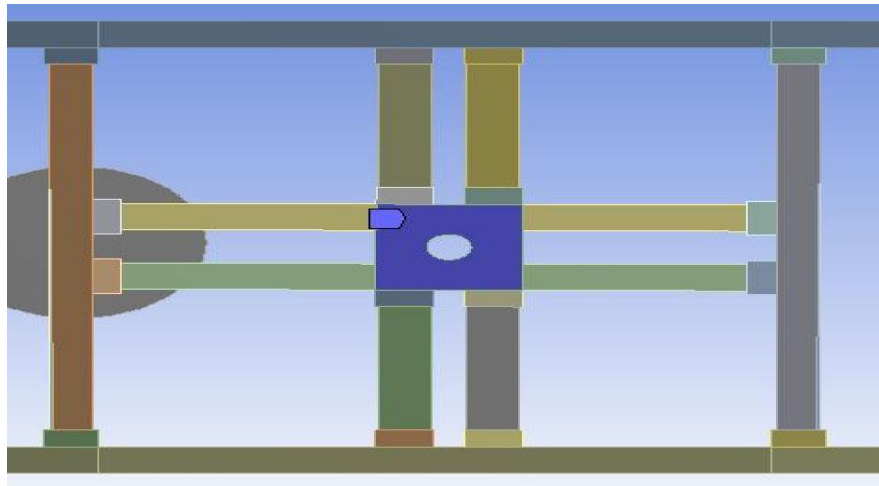

Fig.10. Fixed support

IV. Analysis

Geometry is said to be nonlinear when it has very large aspect ratio [10]. The robot gun support structure used here is having an aspect ratio of approximately more than 9. Therefore it is a problem of geometric non linearity, from Fig. 5 it is clear that aspect ratio is very high for the structure. A component with large deflections due to loads, such as aircraft wing, comes under the category of geometric non-linearity. In geometric nonlinearity geometry of the component is redefined after every load step by adding the displacements at various nodes to the nodal coordinates for defining the true geometry to be used for the next load step [11]. Geometrical nonlinearity arising from large deformations is associated with the necessity to distinguish between the coordinates of the initial and final states of deformation, and also with the necessity to use the complete expressions for the strain components [12]. Substeps mean that the load is applied in steps and stress is calculated for each step. Thus a new [K] matrix is computed at every substeps, effectively modeling the non-linearity.

V. Optimization

The criterion for failure of ductile material is Equivalent Von-misses stress (VMS) [13, 14]. Fig. 11, 12, 13 and 14 shows the results of base run, stress concentration result, path operation plot for unrealistic stresses and path operation plot for predicted stress value for 1st optimization. For optimizing the stress value (VMS) from 282.21 Mpa to 80 Mpa (allowable) various modifications have been done in the structure maintaining the constraints of the structure. A modification like increase in the thickness of particular critical tube is done, change in cross section of critical member and finally addition of extra member at critical locations. Many iterations have been carried out for optimizing the thickness and cross section of critical member. A modification like increase in the thickness of particular critical tube is done, change in cross section of critical member and finally addition of extra member at critical locations.

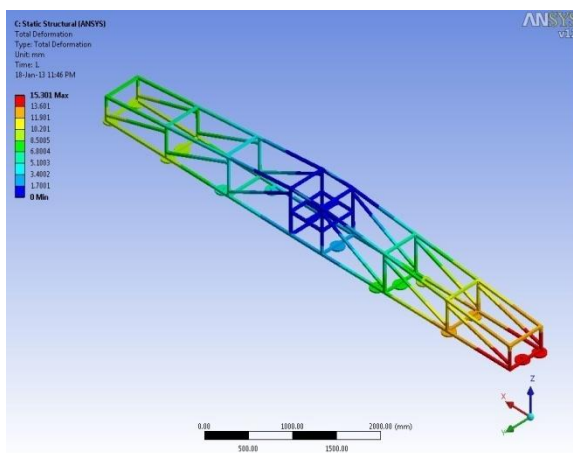

Fig.11. Base Run

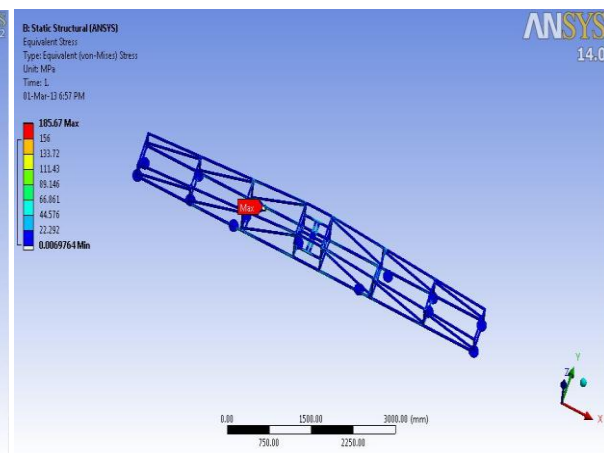

Fig.12. Final Result

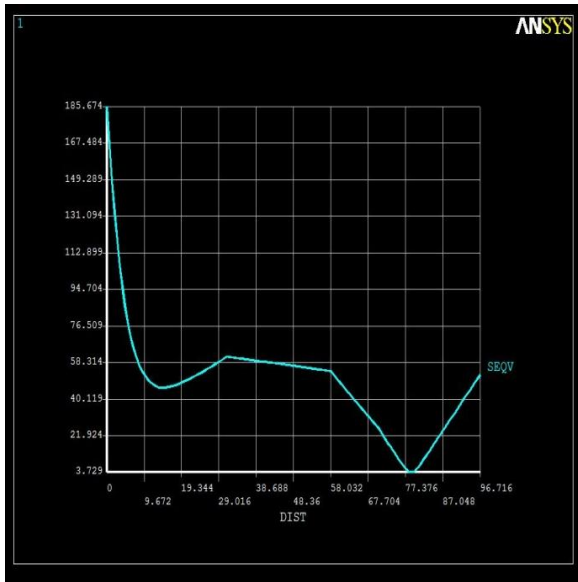

Fig.13. Stress Concentration

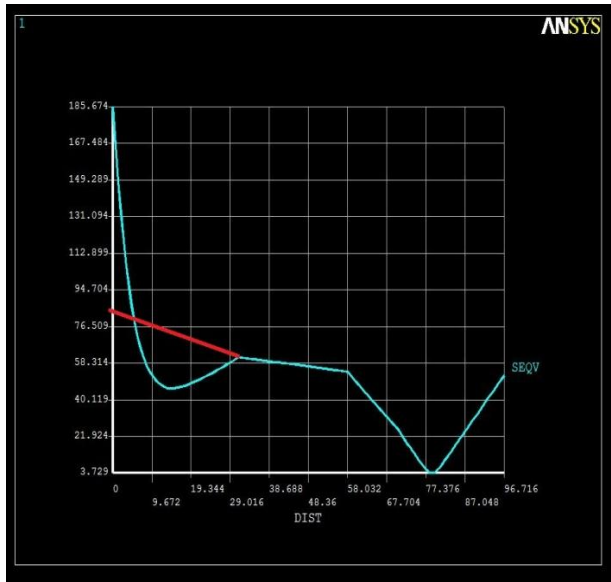

Fig.14. 80Mpa (Predicted stress)

VI. Conclusion

Finite Element Analysis (FEA) enabled the analysis of the support structure using D'Alembert's principle of converting the dynamic load into a equivalent static load in terms of G force. The stress optimization was more specific after identification of stress hot spots, and local optimization of the dimensions, this thus ensured significant cost savings.

Original structure Maximum Stress	Final structure Maximum Stress
282 Mpa	80 Mpa

VII. Future Scope

Using a single robot for a single operation proves to be expensive. Hence for cost optimization, multiple guns are mounted on a single robot and multiple operations are performed. Using above analysis method any support structure can be analyzed by converting dynamic load into a equivalent static load in terms of G force.

REFERENCES

- [1] R. Jaydeep, L. Whitcomb, Structural Design Optimization and Comparative Analysis of a New High-Performance Robot Arm via Finite Element Analysis, International Conference on Robotics and Automation April (1997) 2190-2197.
- [2] M. Palmonella, M. I. Friswell, J. E. Mottershead, A. W. Lees, Finite element models of spot welds in structural dynamics: review and updating, Computers and Structures 83 (2005) 648– 661.
- [3] ANSYS, ANSYS User's Manual Version 14.0, ANSYS Inc, 2011.
- [4] J. F. Abel, M. S. Shephard, An algorithm for multipoint constraints in finite element analysis, International Journal for Numerical Methods in Engineering 14(1979) 464–467.
- [5] Information on <http://www.gforces.net>
- [6] H.S. Lukatcha, R.M. Echon, M.B. MacIver, P.M. Werchan, G-force induced alterations in rat EEG activity: a quantitative analysis, Electroencephalography and clinical Neurophysiology 103 (1997) 563–573
- [7] Y. Ning, Y. Loke, G. Mckinnon, Fabrication and characterization of high g-force silicon peizoresistive accelerometers, Sensors and actuators 48(1995) 55-61.
- [8] P. Dizio, J. R. Lackner, Influence of gravito-inertial force level on vestibular and visual velocity storage in yaw and pitch, Vision research 32(1992) 111–120.
- [9] S. C. Fowler, Effects of pimozide on emitted force, duration and rate of operant response maintained at low and high levels of required force, Pharmacology Biochemistry and Behavior 25(1986) 615–622.
- [10] N. S. Gokhale, S. S. Deshpande, S. V. Bedekar, A. N. Thite, Practical Finite Element Analysis, First Edition, Finite to Infinite, Pune, 2008.
- [11] Carlos Felippa, Geometric Non Linear Analysis of ISO-P quadratic element, University of Colorado at Boulder, 2011.
- [12] S. Ramachandran, T. Nagarajan, N. Siva Prasad, Finite element approach to the design and dynamic analysis of platform type robot manipulators, Finite Elements in Analysis and Design. 10 (1992) 335-350.

- [13] G. J. Chung, D. H Kim, H. Shin, H. J. Ko, Structural Analysis of 600Kgf Heavy Duty Handling Robot, IEEE Conference on Robotics, Automation and Mechatronics. (2010) 40-45.
- [14] D. H. Kim, G. J. Chung, and C. H. Park, Analysis of Heavy Duty Robot for Design, KSMTE 2007 Spring Conference Proceedings (2007) 125-130.
- [15] Wang Shijun, Zhao Jinjuan , 2002 “FEM Optimization for Robot Structure” IEEE ICIT’02, Bangkok, THAILAND.
- [16] Gwang-Jo Chung, Doo-Hyung Kim, 2010 “Structural Analysis of 600Kgf Heavy Duty Handling Robot” *IEEE Conference on Robotics, Automation and Mechatronic*.
- [17] Xiaoping Liao, Changliang Gong, Yizhong Linl, Weidong Wang , 2010 “The Finite Element Modal Analysis of the Base of Welding Robot”, IEEE 978-1-4244-6542-2
- [18] Zhijun Wu, Kailiang Lu, Huiqing Qiu, 2011 “Finite Element Comparative Analysis of Two Doorframe Structures in Container Crane” IEEE 978-1-4244-9439-2/11