

Non Linear Stress Analysis

Md Sadiqul Hasan Talukder

Department Of Mechanical Engineering Rajshahi University Of Engineering & Technology, Bangladesh.

ABSTRACT: This research work deals with the implication of modern retailing at not only in Dhaka, Bangladesh but also the whole district in Bangladesh with main objectives to find out technological activity, impact on modern welfare..

Keywords: Nonlinearity, Deformation, Stiffness, Load, Linear Techniques

I. INTRODUCTION

What is linear analysis? A proportional analysis. For example if I say that a moment M is generating a deflection of D , and what would be the moment acting on the beam if the deflection is $2D$? It will be $2M$. Quite simple right? This analysis is called linear analysis. All the principle of superposition are also valid. Let us say dead load is causing a beam deflection the beam by $1''$ and live load is causing a deflection of $0.5''$ and if I ask you what will be the sum of deflection cause by the two loads? It will be $1 + 0.5 = 1.5''$. This is pretty simple, principle of superposition. This all can happen because the stresses are proportional to strains. Take an example of mathematical equation of a straight line.

$$y=mx$$

Now if I say that the value of slope is known and I give a particular value of x , can you figure out the value y ? Of course yes. And this can be done in a single step. No repetition is required. Now replace x with strain and y with stress and m is the stiffness of material. The equation of the same straight line becomes:

$$\sigma=Es \epsilon$$

So this is why linear analysis is simple. If you know the deformation for 1 unit of load and if you wish to find out the deformation for 5 units of load, you just multiply the deformation by 5 and you have your results. This will reduce the time and effort put into analysis. It will give you sometimes conservative results and sometimes inaccurate as well. It will justify inaccurate in Nonlinear analysis.

II. HEADINGS

Material Nonlinearity

When the materials move into the zone beyond its yield strengths, it no longer behaves in a linear fashion.

There are many things that happen when material go into this zone:

- **Permanent deformations:** This means that when the material is unloaded it will not go back to its original shape or position. For example if you take a plastic bag and stretch it, after a certain point even if you release the bag you will see the permanent stretch marks. This is called permanent deformation.
- **Cracking:** Generally this occurs in linear design as well, but we neglect the cracking of concrete, even though we still consider the reduced stiffness of members while doing seismic design, but still it is an assumed value. While in nonlinear analysis we monitor the cracking and so concrete will crack and member will start losing its stiffness.
- **Beam rotations:** When a beam is subjected to moments greater than its capacity, it no longer resists the moments, instead it rotates and forms a plastic hinge and start dissipating energy. This is a part of material nonlinearity but for beams it is called backbone curve (aka F-D relationship). In case of linear design we do not case for anything greater than the capacity of the member.
- **Energy Dissipation:** In linear analysis, energy dissipation is in the form of strain energy, while in case of nonlinear analysis it is in the form of inelastic energy in addition to strain energy dissipation.

III. INDENTATIONS

All physical processes are inherently nonlinear to a certain extent. For example, when you stretch a rubber band, it gets harder to pull as the deflection increases; or when you flex a paper clip, permanent deformation is achieved. Several common every day applications like these exhibit either large deformations

and/or inelastic material behavior. Failure to account for nonlinear behavior can lead to product failures, safety issues, and unnecessary cost to product manufacturers.

Nonlinear response could be caused by any of several characteristics of a system, like large deformations and strains, material behavior or the effect of contact or other boundary condition nonlinearities. In reality many structures exhibit combinations of these various nonlinearities. MSC Software provides solutions to help you simulate accurately and efficiently systems with any or all of the nonlinearities, with applications encompassing multiple industries.

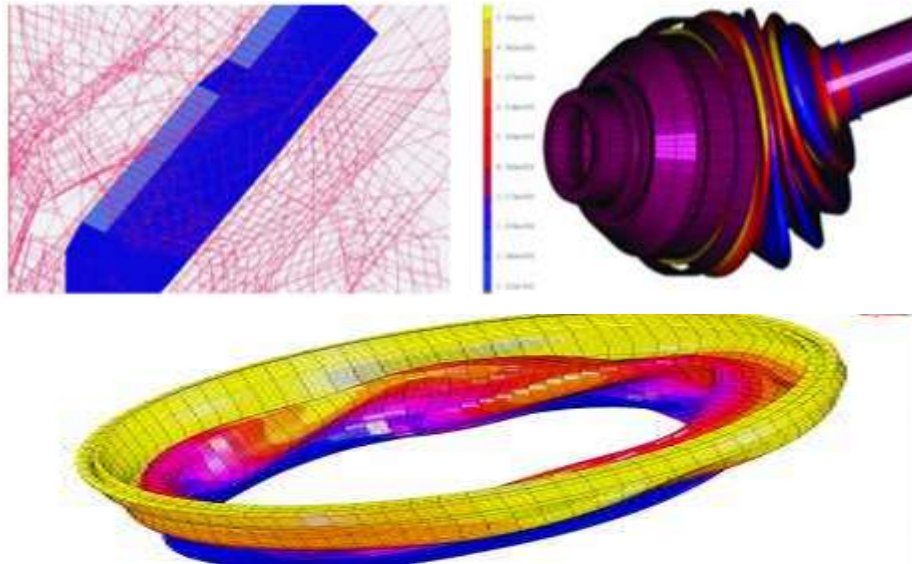

Structures whose stiffness is dependent on the displacement which they may undergo are termed geometrically nonlinear. Geometric nonlinearity accounts for phenomena such as the stiffening of a loaded clamped plate, and buckling or 'snap-through' behavior in slender structures or components. Without taking these geometric effects into account, a computer simulation may fail to predict the real structural behavior.

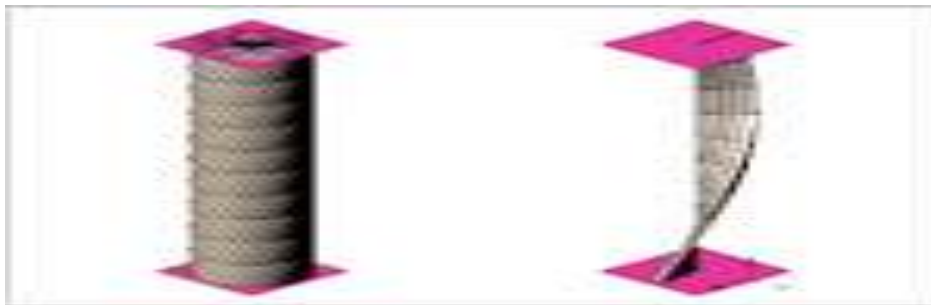

Fig: Twisting Of A Beam

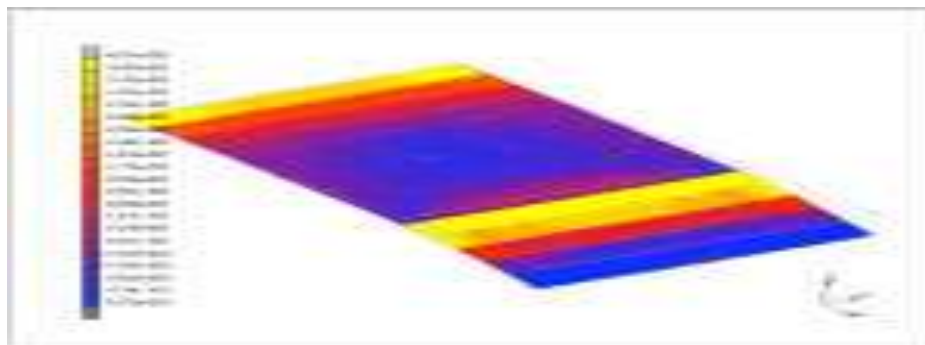

Fig: Bending Of A Plate Shifted With Beams

Material Nonlinearity refers to the ability for a material to exhibit a nonlinear stress-strain (constitutive) response. Elasto-plastic, hyperelastic, crushing, and cracking are good examples, but this can also include

temperature and time-dependent effects such as visco-elasticity or visco-plasticity (creep). Material nonlinearity is often, but not always, characterized by a gradual weakening of the structural response as an increasing force is applied, due to some form of internal decomposition.

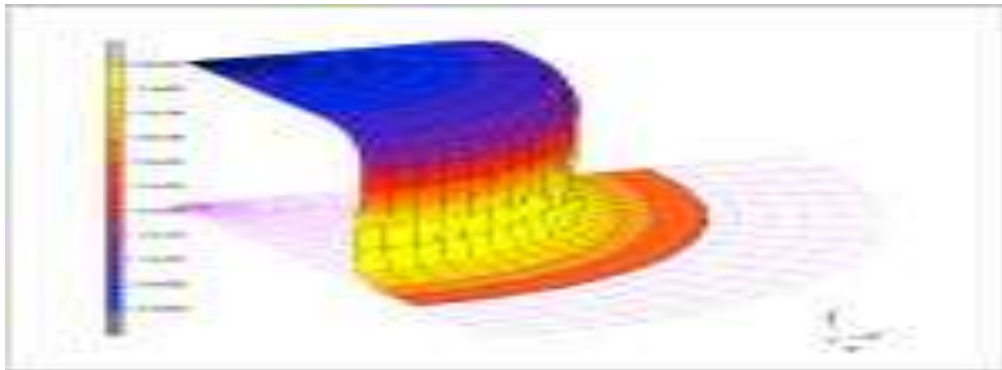

Fig: Sheet Drawing

Nonlinear stress analysis calculates the stresses and deformations of products under the most general loading and material conditions for:

1. Dynamic (time dependent) loads
2. Large component deformations
3. Nonlinear materials, such as rubber or metals, beyond their yield point

Nonlinear analysis is a more complex approach, but results in a more accurate solution than linear analysis, if the basic assumptions of a linear analysis are violated. If the linear analysis assumptions are not violated, then the results of a linear and nonlinear analysis will be the same.

The time component when carrying out a nonlinear analysis is important, both in controlling the loading (individual load components can be active at different times) and in capturing the response to an impulse load of impact. SOLIDWORKS Simulation provides either an automatic or a manual time control method with a force, displacement, or arc length convergence control. You get power and flexibility to solve challenging and complex simulation problems simply in a straightforward manner.

SOLIDWORKS Simulation uses finite element analysis (FEA) methods to discretize design components into solid, shell, or beam elements and uses nonlinear stress analysis to determine the response of parts and assemblies due to the effect of:

- Forces
- Pressures
- Accelerations
- Temperatures
- Contact between components

Loads can be imported from thermal and motion Simulation studies to perform multiphysics analysis.

In order to carry out stress analysis, component material data must be known. The standard SOLIDWORKS CAD material database is pre-populated with materials that can be used by SOLIDWORKS Simulation, and the database is easily customizable to include your particular material requirements.

While the Nonlinear Analysis is solving, you can visualize intermediate results. By getting visual feedback of the results as the solution progresses, you can make decisions to either stop the simulation and make adjustments to the input, or let the solver proceed with the current settings.

Certain types of buckling and creep analyses, nonlinearity is required. In some cases, the allowable load can be increased using nonlinear techniques. Other times the inclusion of nonlinearity adds unneeded complexity and expense to the numerical model without any real benefit. We can use a simple case study to explore the difference in results from the analysis techniques selected and to evaluate the required solution effort.

We'll consider a simple lifting lug, consisting of a 6" x 4.5" x 0.75" piece of plate steel with a 1.5" ID hole welded to the shell of a 0.5" thick 60" OD shell. Figure 1 shows the lug, shell and weld geometry.

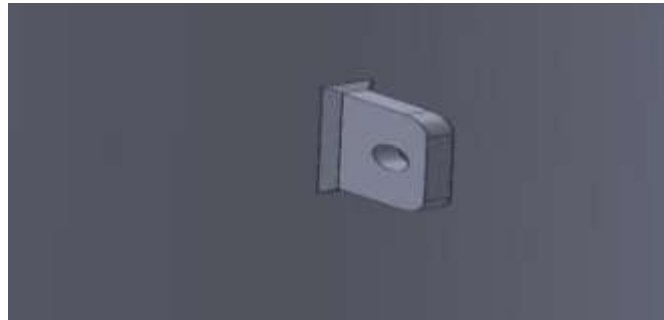

Figure 1: Lifting Lug Geometry with Weld

The materials of construction are SA-516 Gr. 70, with the weld having strength equal to or greater than the primary materials of construction. Three cases will be considered, using the methods specified in the ASME Boiler and Pressure Vessel Code (the Code), Section VIII, Division 2, Rules for Construction of Pressure Vessels, Alternative Rules.

Case 1 - Paragraph 5.2.2 – Elastic Stress Analysis Method

Case 2 - Paragraph 5.2.3 – Limit-Load Analysis Method, and

Case 3 - Paragraph 5.2.4 – Elastic-Plastic Stress Analysis Method

The results from the analysis of each of these cases are used below to establish the allowable load that can be applied to the lug along the longitudinal axis of the vessel.

The first step in conducting the analyses is to construct a finite element (FE) model of the lug, weld and shell. For this case, a half-symmetry mesh, suitable for elastic and plastic analyses, is constructed. The figure below shows the quarter-symmetric mesh developed for the study. This mesh is mirrored to construct the half-symmetry model. The analysis model contains 52,413 nodes and 44,076 elements.

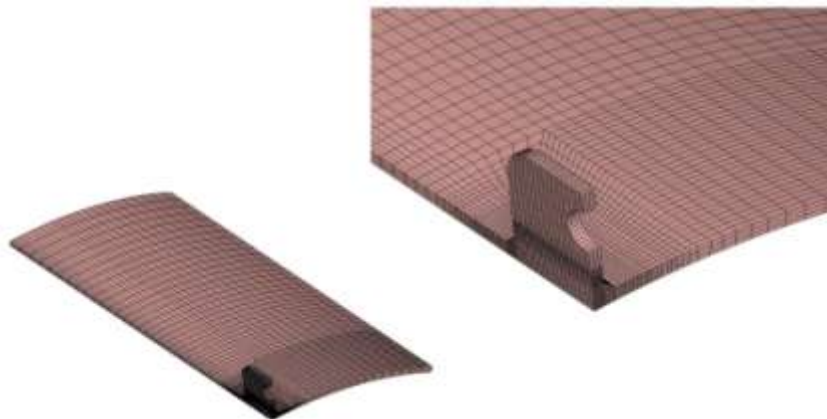

Figure 2: FE Mesh

Next, the material properties for the analysis are established from the Code, Materials Properties (Customary). The table below shows the relevant material properties for the analyses.

Table 1: Material Properties Used for Analysis

Property	Symbol	Value	Units
Density	ρ	0.28	lb/in ³
Elastic Modulus	E	29.4×10^6	psi
Allowable Stress	S	20	ksi
Yield Stress	S _y	38	ksi
Strain Hardening Modulus	SHM	50	ksi ⁻¹

The last step before conducting the analyses is to apply the model boundary conditions (BCs). The constraints are applied using a cylindrical coordinate system, with the system aligned with the centerline of the shell. A longitudinal load is applied to the hole in the lug, with the magnitude of the load varied for each analysis to meet the maximum stress limits defined by the Code. The figure below shows the BCs applied to the model.

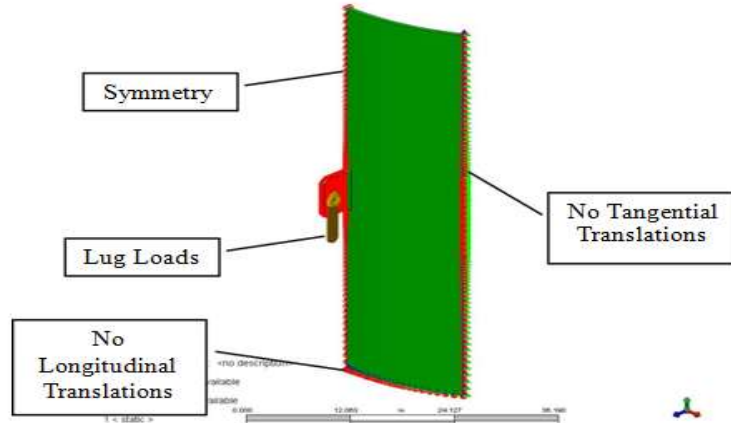

Figure 3 - Models BCs

The following sections contain the results of the analyses performed on the model.

Case 1 - Paragraph 5.2.2 – Elastic Stress Analysis Method

To perform the linear-elastic analysis, a 1,000 lb nominal load is applied to the inside surface of the lifting lug’s hole, as shown in Figure 3. Figure 4 shows the von Mises stress results from the elastic analysis of the lifting lug.

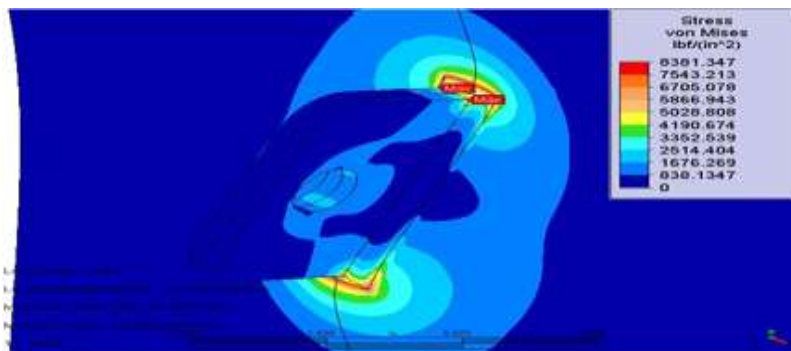

Figure 4 –Elastic Stress Analysis Results for 1,000 lb Applied Load

The Peak Stress Intensity (PL + Pb + Q + F) - as defined in Section VIII, Div. 2, Figure 5.1 - is 8.4 ksi. Since the model is linear, this stress magnitude translates to a maximum stress of 8.4 psi/lb applied load. This value, combined with a known lifting load, could be used to calculate a fatigue life for the lug using the procedures in Section VIII, Div. 2, Paragraph 5.5.3. Figure 5.1 from the Code also lists the criteria used to evaluate the remaining stresses. In this case, due to the vicinity of the stresses to the discontinuity, all stresses are considered to be local. From the table, the local membrane stress limit (PL) is 1.5S, and the local membrane plus bending (PL + Pb + Q) is SPS. From the information provided above and the Code definitions, these stresses are 30 and 76 ksi, respectively. Stress classification lines (SCLs) are used to evaluate the stress magnitudes, as specified in the Code. These lines are constructed at the ring extents, defined in WRC Bulletin 429, “3D Stress Criteria Guidelines for Application”. Figure 5 shows typical SCLs of interest for the analysis².

² **Note:** Additional SCLs would be required for a complete analysis.

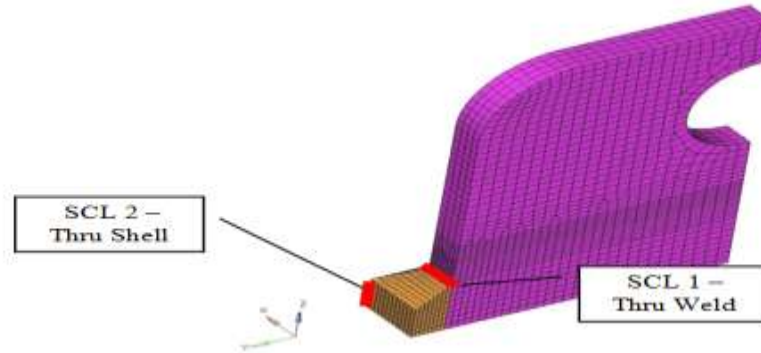

Figure 5 - SCLs Used for Analysis

The stresses are linearized using the built-in software utility. The results of these inquiries are summarized in the table below.

Table 2: Summary of Linear Stress Classifications

SCL #	PL (ksi)	PL + Pb + Q (ksi)
1	5.35	8.00
2	1.50	5.55

The Code provides some guidance on the interpretation of stresses for lugs in Section VIII, Div. 2, Paragraph 4.15.5.2, which includes references to Part 5 procedures, four WRC bulletins and the acceptability of other recognized codes. Therefore, the engineer would need to make an informed decision based on these sources to determine the actual allowable stress. Strict interpretation of the results in Table 2, within the context of the Code allowables, shows that the controlling stress is PL on SCL 1. Using the maximum allowable stress of 30 ksi, the lug can be rated for 11,200 lbs (30 ksi/5.35 ksi/1,000 lb load * 2 for symmetry).

In this case, with the controlling stress at the upper weld toe, the stress does not occur on a pressure boundary. Since the stress is not on a pressure boundary, the controlling stress may be governed by the User’s Design Specification rather than by Code allowable values. Two typical specifications for room temperature stresses are:

1. The maximum membrane stress through any net section not encompassing a pressure boundary shall not exceed the yield stress of the material.
2. The maximum stress through any net section on the pressure boundary shall meet the requirements of Section VIII, Div. 2, Figure 5.1, using of SPS to evaluate PL + Pb + Q.

Note, the specifications above are likely mutually exclusive and would not typically be contained in the same User’s specification. Both of these criteria can be quantified using the information in

Table 2, as shown in the table below.

Table 3: Summary of Controlling Loads from User’s Design Specification

Specification #	Controlling SCL	Limit Stress (ksi)	Allowable Load (lbs)
1	1	38	14,200
2	2	76	27,380

As can be seen, using the elastic analysis method - depending on the selection of limiting criteria - the allowable load for the lug can vary between 11,200 and 27,380 lb.

Case 2 - Paragraph 5.2.3 – Limit-Load Analysis Method

To perform the limit-load analysis, the model physics are modified to include small-displacement yield strains with a von Mises hardening rule, as specified in Code Paragraph 5.2.3. Figure 6 shows the stress state at the limit-load. The regions in red are over yield.

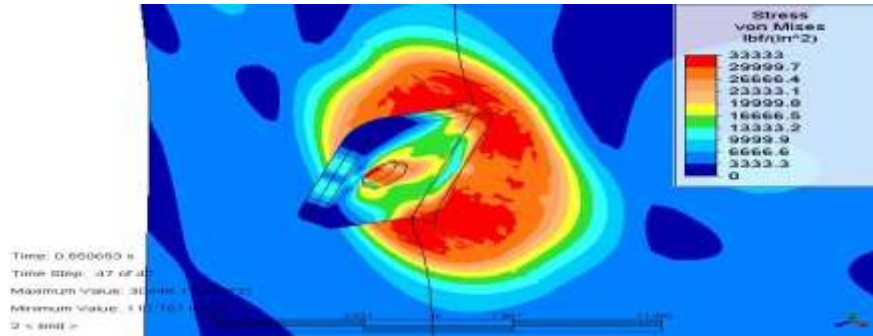

Figure 6: Complete Lug Stress State at Limit-Load (20 x Displacement Scale)

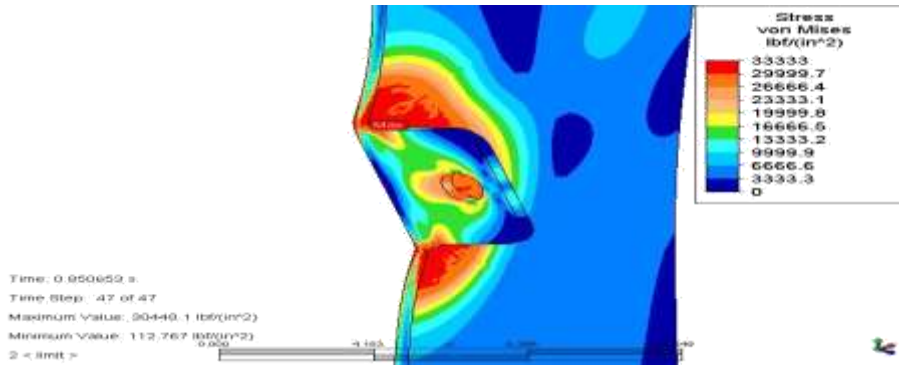

Figure 7: Close-up of Lug Stress State at Limit-Load (20x Displacement Scale)

As can be seen from the figures, with the inclusion of nonlinearity, the maximum stress location has moved from the toe of the weld on the lug to the shell. From the close-up it can be seen that the structural instability is predicted to occur through the formation of a complete yield surface through the shell at the toe of the weld. This is shown by the merger of the red (yield) contours initiating from the outer fibers of the shell. Using the 1.5S criterion from the Code, the load magnitude required to cause structural instability (queried from the model) was 37,600 lb.

Case 3 - Paragraph 5.2.4 – Elastic-Plastic Stress Analysis Method

The Code allows for the consideration of two cases using the elastic-plastic analysis method: elastic perfectly-plastic without a SHM or elastic-plastic with a SHM. The SHM can be either linear or a piecewise function. To conduct the analyses, the model physics are updated to include large-displacement yield strains with a von Mises hardening rule. A constant SHM was considered for both analyses. A SHM of zero was used for the elastic perfectly-plastic analysis and the value of 50 ksi from Table 1 was used for the second model. (The Code does allow for a complete nonlinear model with the stress-strain curve derived from coupon tests of the material³.) Analyses are then conducted with the two SHMs to determine the load resulting in static instability. The elastic limit was set to the Code allowable material yield (S_y) for both analyses.

The results for the analysis conducted with an elastic-perfectly plastic material model are shown in Figures 8 and 9.

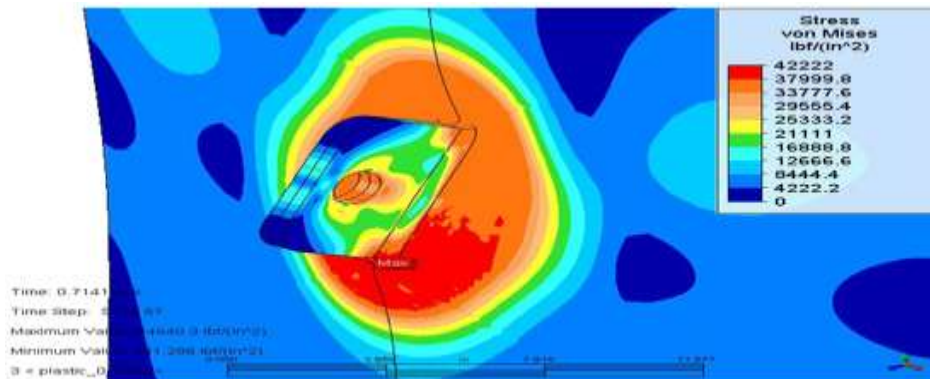

Figure 8 Elastic Perfectly-Plastic Failure Stresses (20x Displacement Scale)

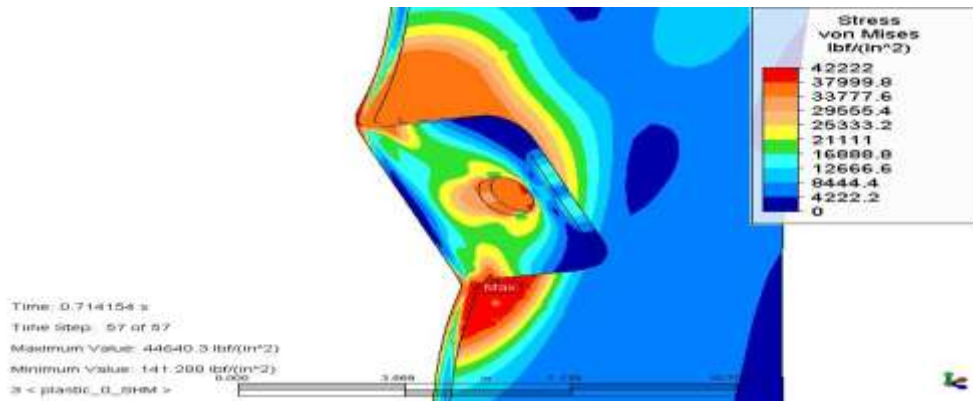

Figure 9: Elastic Perfectly-Plastic Failure Stresses, Inside View (20x Displacement Scale)

³ NOTE: For non-nuclear pressure vessels it is very uncommon to have access to test coupon material data from the heats (batches) that will be used for the vessel’s construction. More data is available from the Code for situations requiring it, such as isochronous stress-strain curves for many materials operating in the creep range.

As can be seen from the figures, the overall stress field is similar to the stress field computed at failure for the limit-load analysis. The maximum stress occurs in the toe of the weld; however, in this case the stress occurs at the bottom, rather than the top of the lug. For the elastic, perfectly-plastic analysis, widespread yielding only occurs at the bottom of the lug, rather than on both sides, as predicted by the limit-load model. The failure mode for this case is the formation of a plastic hinge through the thickness of the shell, as shown by necking occurring on the inside surface of the shell, opposite the toe of the weld. The allowable load predicted from this analysis was 48,550 lb.

Figures 10 and 11 show the results of the elastic-plastic analysis performed with the SHM from Table 1.

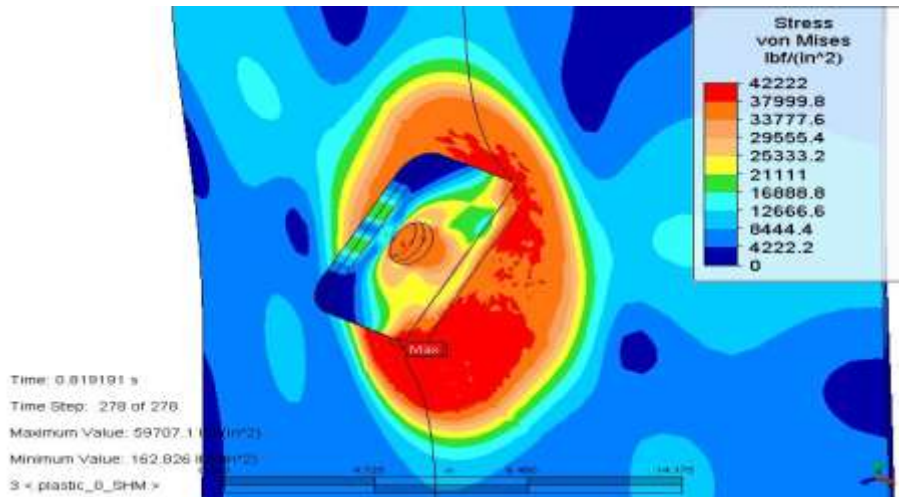

Figure 10: Elastic-Plastic Analysis with non-Zero SHM Failure Stresses (20x Displacement Scale)

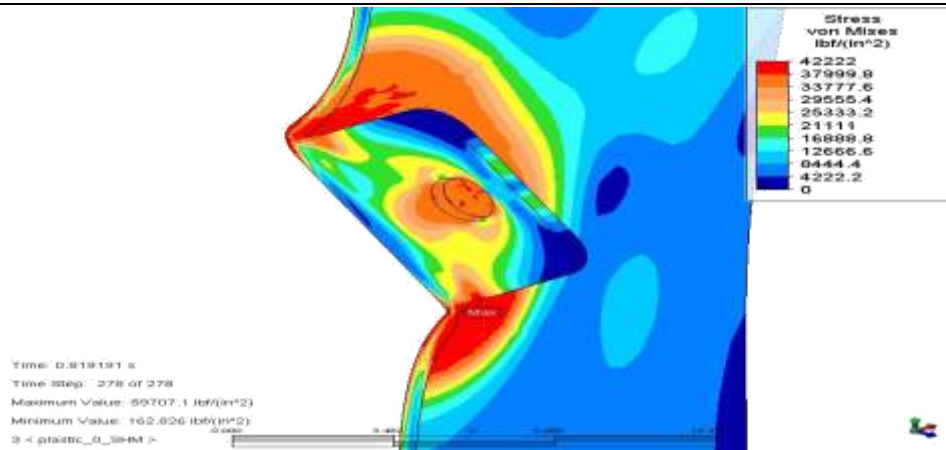

Figure 11: Elastic-Plastic Analysis with non-Zero SHM Failure Stresses, Close-up (20x Displacement Scale)

As can be seen from the figures, the failure stress distributions for the elastic-plastic analysis with a non-zero SHM are similar to the distributions calculated using the elastic perfectly-plastic analysis. Once again the maximum stress occurs at the toe of the weld at the bottom of the lug. As shown in Figure 11, the failure mode is the creation of a plastic hinge through the shell, evidenced by severe necking at this location. Necking and folding has also occurred at the top of the lug, but has caused less plastic damage than at the bottom of the lug. Querying the model loads at failure indicates an allowable load of 55,000 lb.

IV. Discussion

From the allowable load values predicted above, it is apparent that the use of nonlinear analysis techniques increased the allowable load from a minimum elastically calculated load of 11,200 lb to a nonlinearly calculated maximum allowable load of 55,000 lb. It should be noted that the loads calculated using the procedures in this case summary are static, dead loads. As such, good engineering practice would include determining a knock-down factor to include such effects as dynamic / impact lifting loads and changes in the load’s line-of-action. It is likely that additional analyses would need to be performed to quantify these effects’ impact on the lug’s allowable load. That said, with the geometry considered in this case study, the use of nonlinear analysis allows the justification of a significantly higher allowable load for the lug. It should be noted that the effects of using nonlinear techniques are very problem-dependent. It is difficult to quantify the effects without first performing the analysis.

More discussion on the differences in techniques is provided below, based both on the results of this case study and PMI’s past experience.

The primary detriment to the use of nonlinear techniques is the analysis cycle time. For this case, the initial model was constructed to allow consideration of elastic and plastic effects, including appropriate sectioning for linearization. Therefore, the only increased expense for the nonlinear analyses was a minor amount of analyst time and CPU time. The table below summarizes the wall clock time for each analysis. Each analysis was performed in-core with 12 CPUs.

Table 4: Summary Of Analysis CPU Times

Case	Wall Time (min)
Paragraph 5.2.2	1
Paragraph 5.2.3	140
Paragraph 5.2.4, w/ Elastic Perfectly-Plastic Properties	197
Paragraph 5.2.4, w/ SHM	256

As can be seen from the table, the inclusion of nonlinear effects has a significant impact on the compute time required, with nonlinear techniques requiring ~150 – 250x the amount of CPU time as linear techniques.

The following lists serve to highlight additional differences between the use of linear and nonlinear techniques.

Linear Techniques – Pros

- Lower mesh density - The mesh densities required to accurately predict linearized stress values are less than those required to consider plasticity. Therefore, these models tend to be smaller, reducing the

computational resources required for solution.

- Simplified mesh convergence studies – Mesh convergence studies, using a comparison of results, either smoothed vs. non-smoothed or the change in peak stress intensities between revisions, are relatively simple and quick.
- Case combination - The results from multiple linear analyses can be combined using superposition techniques. This allows for the quick evaluation of a number of load cases, as required by the Code.
- Use in additional calculations - The results from linear analyses can be easily used for additional calculations such as evaluation of fatigue life, as specified in Section VIII, Div. 2, Paragraph 5.

Linear Techniques – Cons

- **Requires stress classification, therefore:**
 - The software selected for the analysis must have the ability to linearize stresses. In fact, if you want to perform pressure vessel analysis, the ability to linearize stresses becomes the most necessary feature in selection of a software package. Otherwise, the software cannot be used to evaluate stresses in the context of the Code.
 - Requires detailed knowledge for classification of stresses:
 - The analyst must have knowledge in classifying stresses as local or global, peak or average, and in selecting the appropriate limits.
 - The model constructor must have knowledge in the construction of geometry and grids so that SCLs are present at logical locations for stress evaluation.
 - Post-processing is burdensome. Linearization of stresses is a manual technique, requiring evaluation at many locations. We have seen analysis reports with massive appendices containing table after table of linearized stress values. While these tables can be parsed to only present the worst-case stresses within the main body of the analysis report, the amount of information required for evaluation is daunting and the preparation and evaluation of this information may not be the best use of your engineer's time.

Nonlinear Techniques – Pros

- Simplified post-processing - As shown in this case study, the results from nonlinear analyses can be encapsulated in one number, or a simple go / no-go decision. This simplifies communication of the analysis results to all stakeholders.
- Increased allowable loads - In some cases the allowable load calculated using nonlinear techniques is significantly greater than the load predicted with linear techniques. For this study, increasing the amount of lug material during design and fabrication to redistribute and decrease stresses would be simple and cheap. If instead, a controlling load caused high stresses throughout a part where a global change in material thickness would be required to meet elastically allowable stresses, the cost difference for vessel fabrication with thinner materials can easily be used to justify the use of nonlinear techniques.

Nonlinear Techniques – Cons

- Requires a mesh suitable for nonlinear analysis.
- Detailed consideration of plastic effects requires a higher mesh density than linear stress evaluation. While acceptable results can be achieved by just “meshing the hell out of it,” this modeling technique will result in long, non-optimized analysis cycles.
- Mesh density studies are more complicated. Since plasticity is considered, there is little to no value in a direct comparison of maximum predicted stress.

Increased analysis cycle time – As with any analysis, evaluation of stresses using nonlinear techniques requires multiple analyses. As described above, multiple nonlinear analyses will need to be conducted to ensure that a suitable mesh density has been selected for the analysis. Additionally, to allow informed engineering decisions, it is usually necessary to use both limit-load and elastic-plastic techniques to predict the unstable load.

Considering the information presented above, nonlinear techniques can be useful in the analysis of pressure vessels. The benefit of employing advanced techniques cannot be easily estimated at the outset of the analysis, and it is possible, in the odd case, to predict a lower allowable load than that predicted with linear techniques. Therefore, most engineering analyses use the following procedures:

- Initial analysis using Code calculations – In this step a package such as Compress is used to evaluate the vessel using the procedures specified in Section VIII, Div. 1. Most penetrations and attachments can be qualified using this procedure.
- Development of FE model – In this step an FE model of the vessel is developed with attention paid to include the relevant details for nozzles or attachments that cannot be qualified using Section VIII, Div. 1

techniques. This model will typically contain sectioning required for stress evaluations around the rings, but will not be meshed to all required SCL locations, as these are unknown prior to analysis.

- Refinement of FE model – The mesh density will be increased until convergence is achieved at the maximum stress locations and any additional required SCL locations will be incorporated into the model. This model will be used for all linear qualifications performed on the model.
- Nonlinear analysis of FE model – Specific cases will be determined from the linear analysis of the refined FE model for consideration with nonlinear techniques. Due to the time required for the analyses, it is of considerable benefit to minimize and simplify the cases considered with nonlinear techniques.

Hopefully, the information provided above will allow you to make a more informed decision on whether to consider the use of nonlinear techniques for analysis. It should be evident from the discussion above that PMI has the experience to assist you in performing these complicated analyses.

V. CONCLUSION

Limitation:

1. The maximum stress doesn't exceed the yield strength
2. Non linear analysis cannot be encapsulated in many numbers.

Though it has limitations but modern era is very dependable on these. Specially in pharmaceutical sector these are very effective. Hence, all kinds safety for human is possible by this system. So, this system is absolutely welcome for modern era.