

## Power Quality Improvement Using Active and Passive Power Filters

C.NALINI KIRAN

(Department of EEE, G.Pullaiah College of Engineering and Technology, Kurnool, India)

### ABSTRACT

Power quality standards (IEEE-519) compel to limit the total harmonic distortion within the acceptable range. Active power filter which has been used there monitors the load current constantly and continuously adapt to the changes in load harmonics. Hybrid active filter with proposed control algorithm for three phase hybrid power filter is studied here. It is composed of series active filter connected in series to the line and passive filter connected in parallel with the load. Traditionally, a passive LC power filter is used to eliminate source current harmonics when it is connected in parallel with the load and series active filter will compensate the voltages in the line. The proposed control algorithm is based on the generalized p-q theory. It can be applied to both harmonic voltage injection and harmonic current injection and also it improves the behavior of the passive filter. This control algorithm is also applied to shunt active power filter, combination of series active and shunt active and comparative study has been done. Simulations have been carried out on the MATLAB SIMULINK platform with different filters and results are presented.

**Keywords** - Active filter, Dual-instantaneous power theory, hysteresis controller, harmonics, non-linear load.

### I. INTRODUCTION

A power-quality problem is an occurrence manifested in a nonstandard voltage, current, or frequency deviation that results in a failure or a disoperation's of end-use equipment. Power quality is a reliability issue driven by end users. There are three concerns. The characteristics of the utility power supply can have a detrimental effect on the performance of industrial equipment.

Harmonics produced by industrial equipment, such as rectifiers or ASDs, can have a detrimental effect on the reliability of the plant's electrical distribution system the equipment it feeds, and on the utility system.

The characteristics of the current and voltage produced by ASDs can cause motor problems. While power quality is basically voltage quality, it is not strictly a voltage issue. Since the supply system has a finite, rather than an infinite, strength, currents outside the direct control of the utility can adversely affect power quality. These are harmonic load currents, lightning currents, and fault currents.

Voltage sag is a short-term, few-cycles duration, drop in voltage on the order of more than 10% to less than 90%. Typically, it lasts from 0.5 cycles to a minute. Voltage sags result from the voltage drop, from starting big motors across-the-line, or from a fault on an adjacent power line. Voltage swell is a short-term increase in voltage of a few cycles duration. The magnitude of the increase is more than 10% and less than 80%. A swell can result from a single line-to-ground fault that raises the voltage on the other two phases. It can also result from dropping a large load or energizing a capacitor bank.

### II. NEED FOR HARMONIC COMPENSATION

The implementation of Active Filters in this modern electronic age has become an increasingly essential element to the power network. With advancements in technology since the early eighties and significant trends of power electronic devices among consumers and industry, utilities are continually pressured in providing a quality and reliable supply. Power electronic devices such as computers, printers, faxes, fluorescent lighting and most other office equipment all create harmonics. These types of devices are commonly classified collectively as 'nonlinear loads'. Nonlinear loads create harmonics by drawing current in abrupt short pulses rather than in a smooth sinusoidal manner. The major issues associated with the supply of harmonics to nonlinear loads are severe overheating and insulation damage. Increased operating temperatures of generators and transformers degrade the insulation material of its windings. If this heating were continued to the point at which the insulation

fails, a flashover may occur should it be combined with leakage current from its conductors. This would permanently damage the device and result in loss of generation causing widespread blackouts.

One solution to this foreseeable problem is to install active filters for each nonlinear load in the power system network. Although presently very uneconomical, the installation of active filters proves indispensable for solving power quality problems in distribution networks such as harmonic current compensation, reactive current compensation, voltage sag compensation, voltage flicker compensation and negative phase sequence current compensation. Ultimately, this would ensure a polluted free system with increased reliability and quality.

The objective of this project is to understand the modeling and analysis of a shunt active power filter. In doing so, the accuracy of current compensation for current harmonics found at a nonlinear load, for the PQ theory control technique is supported and also substantiates the reliability and effectiveness of this model for integration into a power system network. The model is implemented across a two bus network including generation to the application of the nonlinear load.

The aim of the system simulation is to verify the active filters effectiveness for a nonlinear load. In simulation, total harmonic distortion measurements are undertaken along with a variety of waveforms and the results are justified accordingly.

### III. NEED OF SHUNT ACTIVE FILTER

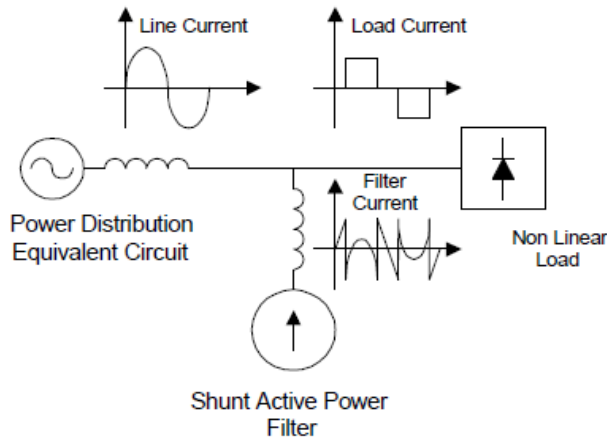

Fig 1: Need of shunt active filter

The inverter in the Shunt Active Power filter is a bilateral converter and it is controlled in the current Regulated mode i.e. the switching of the inverter is done in such a

way that it delivers a current which is equal to the set value of current in the current control loop. Thus the basic principle of Shunt Active Filter is that it generates a current equal and opposite to the harmonic current drawn by the load and injects it to the point of coupling there by forcing the source current to be pure sinusoidal. This type of Shunt Active Power Filter is called the Current Injection Type APF.

### Hybrid Filter

In general, the passive filter was designed only to compensate the source current harmonics; the reactive power was not considered, the concern for compensating voltage harmonics is not high due to the fact that power supplies usually have low impedance. Generally, at the point of common coupling, ridged standards are implemented to ensure a correct level of total harmonic distortion (THD) and voltage regulation is maintained. The problem of compensating for voltage harmonics is to ensure the supply to be purely sinusoidal. This is important for harmonic voltage sensitive devices such as power system protection devices and superconducting magnetic energy storage. Voltage harmonics are related to current harmonics by the impedance of the line. Although compensation of voltage harmonics helps to provide a reduction in current harmonics, this however, does not negate the necessity to current harmonic compensation.

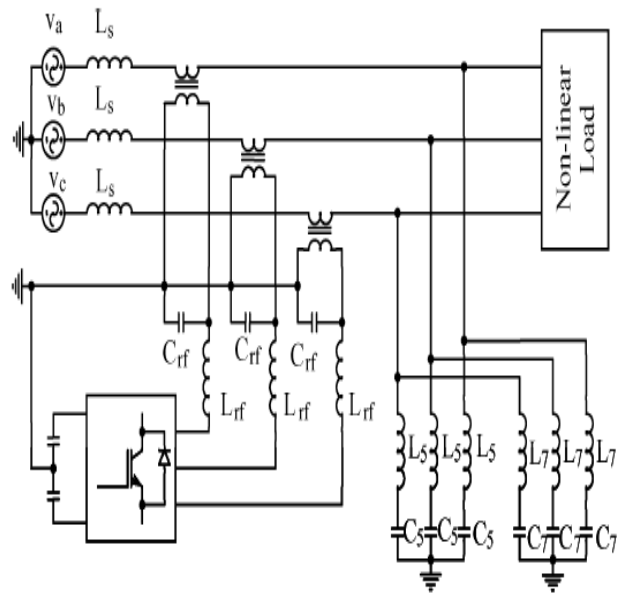

Fig 2: Block diagram of hybrid filter

**IV. DUAL INSTANTANEOUS POWER THEORY**

The proposed control algorithm is based on the generalized p-q theory. It may be applied to both harmonic voltage injection and harmonic current injection. In this algorithm, the compensation voltage references are extracted directly. Therefore, the calculation of the compensation voltage reference will be much simpler than for other control algorithms. In addition, the difficulty of finding the voltage reference gain disappears.

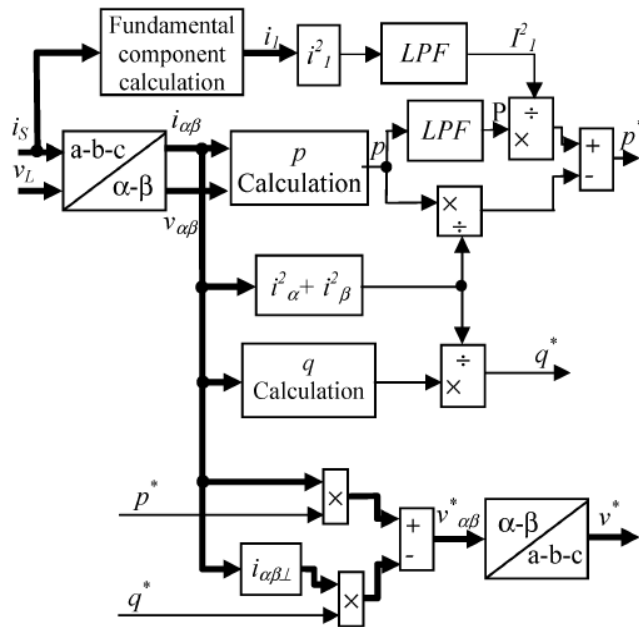

Fig 3: Dual instantaneous power theory

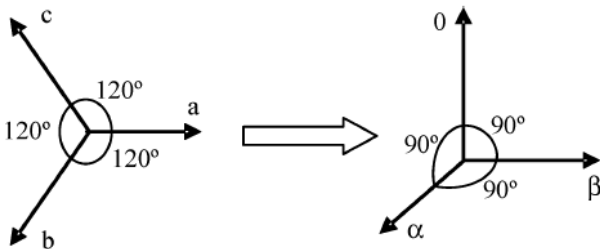

Fig 4: Three phase to two phase conversion

**V. RESULTS AND DISCUSSIONS**

Here simulation has been carried out for series active, shunt active, shunt passive, filters, by using MATLAB SIMULINK. FFT analysis is done, THD is observed for various circuits.

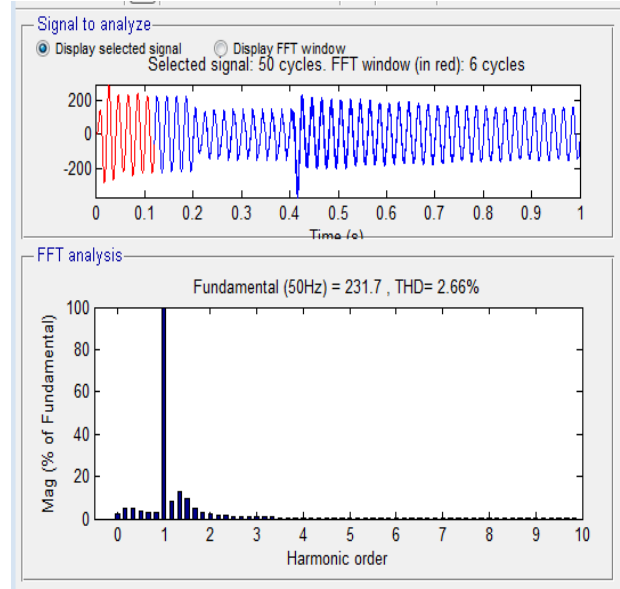

Fig 5: FFT analysis of compensating voltage wave form

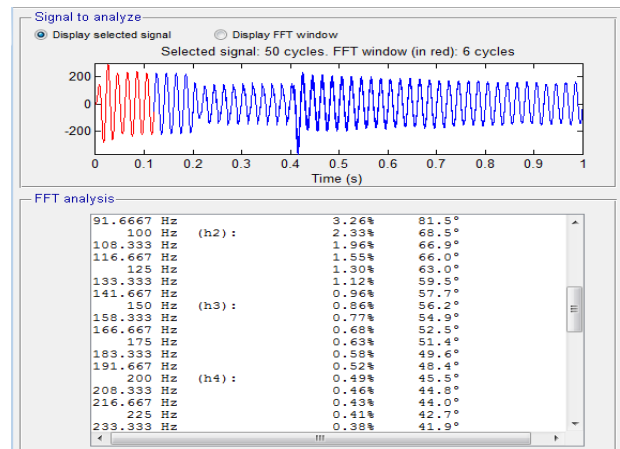

Fig 6: Representation of each and every harmonic

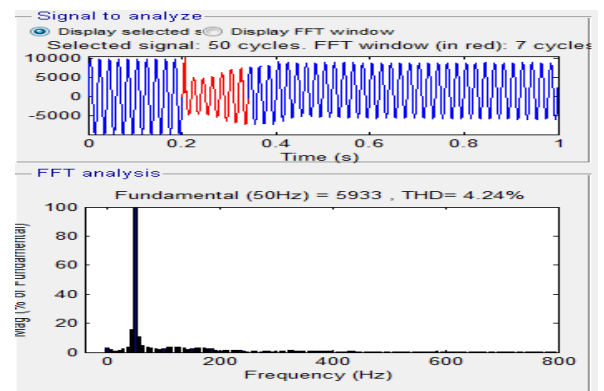

Fig 7: FFT analysis of compensating current

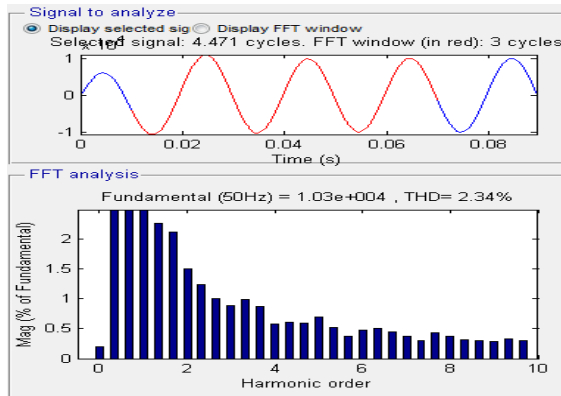

Fig 8: FFT analysis of Compensating voltage wave form at PCC

## VI. CONCLUSION

A dual instantaneous power theory based on instantaneous power theory for hybrid power filters is studied, a Simulink model is designed and total harmonic distortion is calculated using FFT analysis. hybrid power filter which has been used here monitors the load current constantly and continuously adapt to the changes in load harmonics. The performance of three phase hybrid power filter using dual instantaneous power theory is simulated. This control algorithm is also applied to shunt active power filter, combination of series active and shunt active and comparative study has been done. Simulations have been carried out on the MATLAB SIMULINK platform with different filters and results are presented.

## REFERENCES

- [1] F. Z. Peng and D. J. Adams, "Harmonics sources and filtering approaches," in *Proc. Industry Applications Conf.*, Oct. 1999, vol. 1, pp.448–455.
- [2] H. L. Ginn, III and L. S. Czarnecki, "An optimization based method for selection of resonant harmonic filter branch parameters," *IEEE Trans. Power Del.*, vol. 21, no. 3, pp. 1445–1451, Jul. 2006.
- [3] B. Singh, K. Al-Haddad, and A. Chandra, "A review of active filters for power quality improvement," *IEEE Trans. Ind. Electron.*, vol. 46, no. 5, pp. 960–971, Oct. 1999.
- [4] S. George and V. Agarwal, "Optimum control of selective and total harmonic distortion in current and voltage under non sinusoidal conditions," *IEEE Trans. Power Del.*, vol. 23, no. 2, pp. 937–944, Apr. 2008.
- [5] H. Akagi, Y. Kanazawa, and A. Nabae, "Generalized theory of the instantaneous reactive power in three-phase

- circuits," in *Proc. IEEE and JIEE IPEC*, 1983, pp. 821–827.
- [6] Generalized theory of the instantaneous reactive power in three-phase circuits," in *Proc. IEEE and JIEE IPEC*, 1983, pp. 821–827.
- [7] A. Luo, Z. Shuai, W. Zhu, R. Fan, and C. Tu, "Development of hybridactive power filter based on the adaptive fuzzy dividing frequency-control method," *IEEE Trans Power Del.*, vol. 24, no. 1, pp. 424–432, Jan.2009.
- [8] R. S. Herrera and P. Salmerón, "Instantaneous reactive power theory: A comparative evaluation of different formulations," *IEEE Trans. PowerDel.*, vol. 22, no. 1, pp. 595–604, Jan. 2007.
- [9] Schlabbach, D. Blume, and T. Stephanblome, *Voltage Quality in Electrical Power Systems*, ser. PEE Series. New York: IEE Press,2001.
- [10] L. Gyugyi and E. C. Strycula, "Active AC power filter," in *Proc. IEEE IAS Annu. Meeting*, 1976, pp. 529–529.
- [11] Y. Komatsu and T. Kawabata, "Experimental comparison of pq and extended pq method for active power filter," in *Proc. EPE*, 1997, pp.2.729–2.734
- [12] V. Soares, P. Verdelho, and P. D. Marques, "Active power filter control circuit based on instantaneous active and reactive current  $i_d - i_q$  method," in *Proc. IEEE PESC*, 1997, pp. 106–101.
- [13] Generalized theory of the instantaneous reactive power in three-phase circuits," in *Proc. IEEE and JIEE IPEC*, 1983, pp. 821–827.
- [14] J. W. Dixon, G. Venegas, and L. A. Moran, "A series active power filter based on a sinusoidal current-controlled voltage-source inverter," *IEEE Trans. Ind. Electron.*, vol. 44, no. 5, pp. 612–620, Oct. 1997.
- [15] H. Yang and S. Ren, "A practical series-shunt hybrid active power filter based on fundamental magnetic potential self-balance," *IEEE Trans. Power Del.*, vol. 23, no. 4, pp. 2089–2096, Oct. 2008
- [16] .H. Akagi, "Active harmonic filters," *Proceedings of theIEEE* Volume 93, Issue 12, Dec. 2005 Page(s):2128 – 2141
- [17] J.C. Das, "Passive Filters-Potentialities and Limitations", *IEEE Trans. on Industry Applications*, Vol. 40, no. 1, January 2004, pp. 232-241.