

PV Array Fed SEPIC and VSI Based Power Conversion System for Single Phase Induction Motor Drive

P. Sivaraman^{1*}, Dr. A. Nirmalkumar²

¹Assistant professor (Sr.G), Dept. of Electrical and Electronics Engg. Bannari Amman Institute of Technology, Sathyamangalam, India

² Professor, Dept. of Electrical and Electronics Engg.-INFO Institute of Engineering, Coimbatore, India.

ABSTRACT

This paper proposes an implementation of Single Ended Primary Inductor Converter (SEPIC) converter and Voltage Source Inverter for an Induction Motor using Photovoltaic energy as a source. Generally the larger number of drives employed for industrial and commercial applications are induction motor drives. To run such kind of motor from the PV source, it is proposed to have a DC-DC converter and an inverter circuit as interface circuits. As the PV cell posses the nonlinear behavior, a DC-DC converter with Maximum Power Point Tracker (MPPT) controller is needed to improve its utilization efficiency and for matching the load to the photovoltaic modules. In this paper SEPIC converter (DC-DC converter) with Perturb and Observe MPPT algorithm is used for matching the load and to boost the PV module output voltage. To convert the boosted DC output voltage from PV module into AC, a voltage source inverter with sinusoidal pulse width modulation is implemented on it to attain sufficient voltage to drive single phase induction motor. The simulation work of these SEPIC converter and voltage source inverter fed induction motor circuits have been done using PSIM and MATLAB software. The experimental work is carried out with the SEPIC converter and voltage source inverter to drive the single phase induction motor. A PIC microcontroller is used to generate pulses for controlling the SEPIC converter circuit.

Index Terms: Induction motor, MPPT algorithm, PV cell, SEPIC converter, Voltage source inverter,

INTRODUCTION

The photovoltaic energy system has the advantages of absence of fuel cost, no environmental impacts, low maintenance and lack of noise and also it is a kind of renewable energy system. So it is becoming popular in the recent years, as a resource of energy. Modeling and simulation of PV array based on circuit model and mathematical equations is proposed [9]. As the photovoltaic (PV) cell exhibits the nonlinear behavior, while matching the load to the photovoltaic modules, DC-DC power converters are needed. There are several converter configurations such

as Buck, Boost, Buck-Boost, SEPIC, ĆUK, Fly-back, etc. Buck and Boost configurations can decrease and increase the

output voltages respectively, while the others can do both functions. Buck, Boost, Buck Boost converters as interface circuits are proposed and analyzed in [6]. ĆUK and SEPIC converters are analyzed in [1,7].

When the solar insolation and temperature is varying, the PV module output power is also getting changed. But to obtain the maximum efficiency of PV module it must be operated at maximum power point. So it is necessary to operate the PV module at its maximum power point for all irradiance and temperature conditions. For this purpose Perturb and Observe MPPT algorithm is proposed [8]. According to this MPPT output, the duty ratio of SEPIC converter is varied, that leads to changes in output voltage.

The function of an inverter is to change a dc input voltage to a symmetric AC output voltage of desired magnitude and frequency. To drive the three phase induction motor the output dc voltage of SEPIC converter is converted into AC by means of voltage source inverter.

In this paper PV source fed induction motor drive is proposed with SEPIC converter and voltage source inverter as interface circuits. Perturb and Observe (P&O) MPPT Algorithm is used to extract the maximum power point of PV module [8]. Sinusoidal pulse width modulation technique is employed for the control of voltage source inverter. The overall block diagram is shown in fig1.

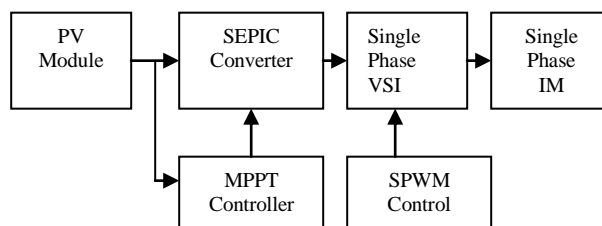

Fig. 1 Overall block diagram

The hardware prototype of SEPIC converter and VSI is constructed to run the single phase induction motor. In the literature survey an analog controller is used to generate the gate pulses and to control the inverter output voltage [3]. In this thesis to generate the gate pulses for the switches, PIC

microcontroller is used in control circuit as given in [4, 5, 14 and 15]. Along with PIC microcontroller, IR2112 driver circuit is needed to generate gate signal for SEPIC converter. The input DC voltage to the SEPIC converter is taken from the power supply unit. The two switches of VSI are gate controlled by using SG3524 PWM controller IC.

II. SEPIC CONVERTER WITH PV AND MPPT

PV system directly converts sunlight into electricity. The basic device of a PV system is the PV cell. Cells may be gathered to form modules or arrays. More sophisticated applications require DC-DC converters to process the electricity from the PV device. These converters may be used to either increase or decrease the PV system voltage at the load. The proposed SEPIC converter operates in boost mode.

A. PV Module Characteristics

The practical equivalent circuit of a PV module is shown in fig.2 [2]., while the typical output characteristics are shown in fig.3.

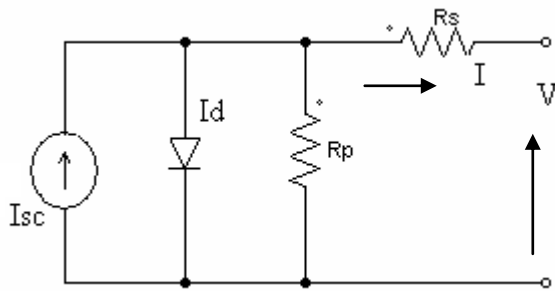

Fig. 2 Equivalent circuit of a PV module

In the equivalent circuit, the current source represents the current generated by light photons and its output is constant under constant temperature and constant irradiance. The diode shunted with the current source determines the I-V characteristics of PV module. There is a series of resistance in a current path through the semiconductor material, the metal grid, contacts, and a current collecting bus. These resistive losses are lumped together as a series resistor (R_s). Its effect becomes very noteworthy in a PV module.

The loss associated with a small leakage of current through a resistive path in parallel with the intrinsic device is represented by a parallel resistor (R_p). Its effect is much less noteworthy in a PV module compared to the series resistance, and it will only become noticeable when a number of PV modules are connected in parallel for a larger system. The characteristic equation which represents the I-V characteristic of a practical photovoltaic module is given below [9]

$$I = I_{pv} - I_o \left[\exp\left(\frac{V + IR_s}{V_t n}\right) - 1 \right] - \frac{V + IR_s}{R_p} \tag{1}$$

Where I and V are the PV cell current and voltage respectively, I_{pv} is the photovoltaic current, I_o is the reverse saturation current of diode, $V_t = N_s k T / q$ is the thermal voltage of the array with N_s cells connected in series, k is the Boltzmann constant ($1.3806 \times 10^{-23} \text{ J/K}$), T is the temperature of the p-n junction, q is the electron charge and n is the diode ideality constant. I_{pv} and I_o are given as follows [9].

$$I_{pv} = \left\{ \left[1 + a(T - T_{ref}) \right] I_{sc} \right\} \left[\frac{G}{1000} \right] \tag{2}$$

$$I_o = I_o(T_{ref}) \left[\frac{T}{T_{ref}} \right]^3 \frac{q E_g}{n k} \left[\frac{1}{T_{ref}} - \frac{1}{T} \right] \tag{3}$$

Where “ a ” is temperature coefficient of I_{sc} , G is the given irradiance in W/m^2 and E_g is the band gap energy (1.16eV for Si). The single PV module specification is given in table I.

TABLE I PV MODULE BPSX150S SPECIFICATIONS

Electrical Characteristics	Value
Maximum Power (P_{max})	150W
Voltage at P_{max} (V_{mp})	34.5V
Current at P_{max} (I_{mp})	4.35A
Open-circuit voltage (V_{oc})	43.5V
Short-circuit current (I_{sc})	4.75A
Temperature coefficient of I_{sc}	$0.065 \pm 0.015\% / ^\circ\text{C}$
Temperature coefficient of V_{oc}	$-160 \pm 20 \text{ mV} / ^\circ\text{C}$

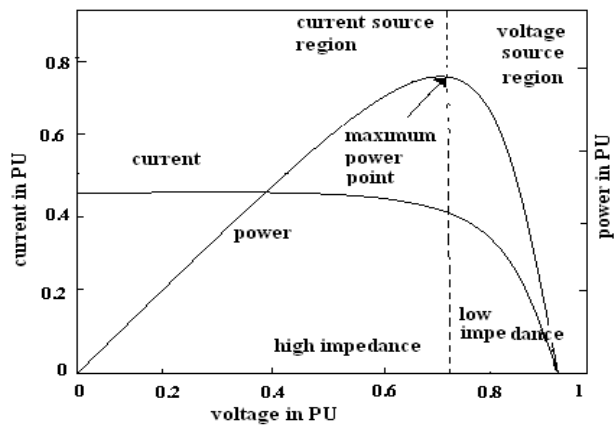

Fig. 3 PV Module IV and PV characteristics

Fig.3 illustrates the I-V and P-V characteristics of the PV array under a given insolation and temperature. As seen in the power versus voltage curve of the module there is a single maximum of power. That is there exists a peak power corresponding to a particular voltage and current. Since the module efficiency is low it is desirable to operate the module at the peak power point so that the maximum power can be delivered to the load under varying temperature and insolation conditions. Hence maximization of power improves the utilization of the solar PV module [2,6]. A maximum power point tracker (MPPT) is used for extracting the

maximum power from the solar PV module and transfers it to the load.

B. MPPT Control Algorithm

There are various types of maximum power point tracking algorithms available. Among them, P&O algorithm is used here, since it has the advantages of high tracking efficiency, low cost, easy implementation etc. In this algorithm a slight perturbation is introduced in the system voltage. Due to this perturbation, the power of the module changes [8]. If the power increases due to the perturbation then the next perturbation is continued in the same direction. After the peak power is reached the power at the next instant decreases and hence after that the direction of perturbation reverses. When the steady state is reached the algorithm oscillates around the peak point [8]. In order to keep the power variation small the perturbation size is kept very small. The algorithm is developed in such a manner that it sets a reference voltage of the module corresponding to the peak voltage of the module. Fig 4 shows the flow chart of P&O algorithm.

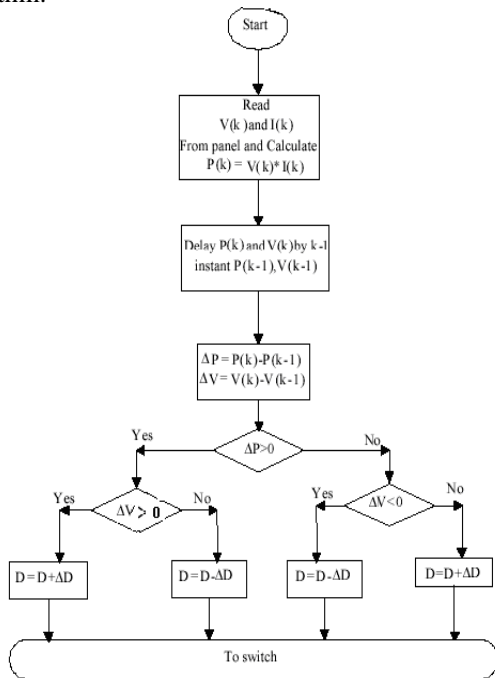

Fig.4 Flowchart of P&O MPPT algorithm

If we observe the power voltage curve of the solar PV module we see that in the right hand side curve where the voltage is almost constant the slope of power voltage is negative ($dP/dV < 0$) where as in the left hand side the slope is positive. ($dP/dV > 0$). The right side curve is for the lower duty cycle (nearer to zero) where as the left side curve is for the higher duty cycle (nearer to unity). After subtraction depending upon the sign of dP [$P(k+1) - P(k)$] and dV [$V(k+1) - V(k)$], the algorithm decides whether to increase the duty cycle or to reduce the duty cycle [8].

C. Modeling of SEPIC Converter

The important requirement of any DC–DC converter used in the MPPT scheme is that it should have a low input-current ripple. Buck converters will produce ripples on the PV module side currents and thus require a larger value of input capacitance on the module side. On the other hand, boost converters will present low ripple on the PV module side, but the load current exhibits more ripple and gives a voltage higher than the array voltage to the loads.

The buck– boost converters can be used where the requirement of load voltage, either low or higher than the array voltage. However, with this converter the input and load currents are pulsating in nature. Furthermore, the load voltage will be inverted with buck–boost or CUK converters. Under these conditions, the SEPIC converter, provide the buck–boost conversion function without polarity reversal, in addition to the low ripple current on the source and load sides.

The SEPIC (Single Ended Primary Inductor converter) topology with PV module and MPPT controller is shown in fig5 and it is proposed the converter is operated in Continuous Current Mode (CCM) [2].The inductance and capacitance values are designed from [10].This converter has two inductors and two capacitors. The capacitor C_1 provides the isolation between input and output. The SEPIC converter exchanges energy between the capacitors and inductors in order to convert the voltage from one level to another. The amount of energy exchanged is controlled by switch, which is typically a transistor such as a MOSFET.

L_1 is the input inductance, L_2 is the output inductance, C_1 is the energy transfer capacitor, C_2 is the output capacitor, V_{in} is the input voltage, V_o is the output voltage, V_{C1} is the voltage across capacitor C_1 , I_{L1} is the current though L_1 and I_{L2} is the current through L_2 .

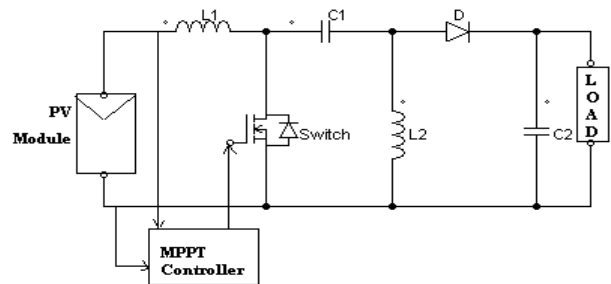

Fig. 5 SEPIC converter topology with PV and MPPT

The duty cycle D can be determined from the steady state condition and the following equation is true:

$$\frac{I_{L1}}{I_{L2}} = \frac{D}{1-D} = \frac{I_{in}}{I_o} \tag{4}$$

TABLE II SEPIC CONVERTER DESIGN SPECIFICATIONS

Parameter	Value
Input Voltage	32V
Output Voltage	220V
Output Current	1A
Duty Ratio	0.8
Switching frequency	25KHz

Assuming an ideal converter in which the input power is the same as the output power, then:

$$P_{in} = P_o \quad (5)$$

$$V_{in} I_{in} = V_o I_o \quad (6)$$

Combining equation (8) and (10), the relationship between input and output voltage is:

$$\frac{V_o}{V_{in}} = \frac{D}{1-D} \quad (7)$$

The converter design specifications are given in table II.

III. SEPIC CONVERTER AND VSI FOR INDUCTION MOTOR DRIVE APPLICATIONS

Output voltage from a voltage source inverter can be adjusted by exercising a control within the inverter itself. The most efficient method of doing this is by pulse-width modulation control (PWM)[16]. In this method, a fixed dc input voltage is given to the inverter and a controlled ac output voltage is obtained by adjusting the on and off periods of the inverter switches.

The PSIM simulation model of SEPIC converter and VSI fed induction motor is shown in fig6. The SEPIC converter output is a boosted DC voltage of PV module output. The output of the SEPIC converter is fed to the three phase voltage source inverter with the help of DC link capacitor. The aim of the DC link capacitor is to maintain the VSI input voltage as constant. The value of this capacitor is designed from the literature [13].

SPWM control is proposed in this paper in which three phase sinusoidal voltage of same magnitude and 120° phase shift is compared with the common triangle waveform. The magnitude of the output voltage of the inverter is controlled by the amplitude of the reference sine wave and hence the amplitude modulation index. The frequency of the inverter output voltage is controlled by the frequency of the reference signal. The current output of the inverter is dependent on the load impedance. The controlled magnitude and frequency of the inverter output voltage is given to the armature of the three phase induction motor. Finally the speed of the machine is measured for the given irradiance and temperature.

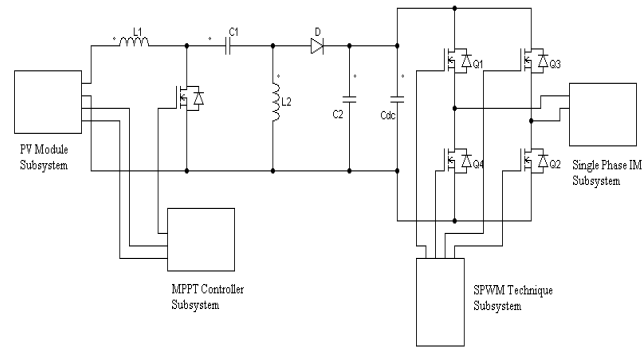

Fig. 6 Simulation model of SEPIC converter and VSI fed induction motor drive

IV. HARDWARE DESCRIPTION

The hardware prototype of SEPIC converter and voltage source inverter is constructed to run a single phase induction motor. Since the cost of the PV panel is high, dc supply for the SEPIC converter is given from the power supply unit. In both the SEPIC converter and voltage source inverter circuits the selected switch is MOSFET.

The control circuit which has the PIC microcontroller unit and driver circuit unit necessitates the power supply circuit module. The PIC microcontroller is given 5V dc as its supply and the driver circuit requires both 5V and 12V dc supply. So it is necessary to construct a power supply circuit module which produces both 5V and 12V dc output. The circuit uses two ICs 7812(IC1) and 7805 (IC2) for obtaining the required voltages.

The main device of controller circuit is a PIC 16F877A microcontroller and the coding for pulse generation is programmed and flash into the microcontroller. The microcontroller is operated at 4MHz clock frequency. The pin diagram of PIC 16F877A microcontroller and the various features of this microcontroller are referred in PIC16F87XA datasheet. Port B of this controller is assigned as output port. Pin no 13 and 14 are connected with the crystal oscillator of 4 MHz frequency. Pin 1 is connected with the reset switch through the 1K resistor. Pin 32 is given with 5V dc supply and 31 is connected with the ground. The coding for pulse generation is written in C and compiled with MPLAB IDE.

Driver circuit used to drive MOSFET switch of the SEPIC converter circuit is constructed with the IR2112 driver IC. IR2112 is a 14 pin IC. The pins 1 and 7 are the output pins and they can be given to the gate terminals of two MOSFET switches. With this IR2112 driver IC we can produce the gate voltage level up to 10-20V. The pins 10 and 12 are receiving the pulses from the microcontroller of amplitude 5V. Pin 9 is given 5V supply and pin 13 is connected with the ground. Again pin 3 is connected with the 12 V supply. Pin 5 and 2 are acting as the return paths of high and low side outputs respectively.

Power circuit of the hardware prototype consists of two circuits such as SEPIC converter and voltage source inverter. Here it is designed to boost the input dc voltage of 12-15V into 200V. The voltage source inverter converts the boosted DC voltage from the SEPIC converter into AC voltage.

The switch used in the SEPIC converter circuit is IRF840 MOSFET. The inductor L1 and L2 are having the values of 121 μ H and is constructed as coupled inductor [12]. Capacitor values are $C_1=100 \mu$ F and $C_2 = 470 \mu$ F. The boosted DC voltage of the SEPIC converter is fed to the single phase voltage source inverter through the DC link capacitor. The DC link capacitor is used to maintain the constant DC voltage in the input side of the inverter. SG3524 IC is used to produce pulses for the two switches of the half bridge inverter. The switches used in the inverter circuit are P55NF06 N channel MOSFET. An inductor is used in this inverter circuit for the voltage balancing of load. The protection circuit consists of diode, resistances and capacitors are also employed in the circuit

V. RESULTS AND DISCUSSIONS

A. Simulation Results

The simulation of SEPIC converter and VSI fed single phase induction motor is done in MATLAB/SIMULINK and PSIM software. For the purpose of the simulation, constant irradiance and temperature is considered for the PV module. Fig 8 shows the SEPIC converter output voltage from the simulation model. It is the boosted Dc voltage of PV module. Also in this fig the SPWM technique pulses are shown. When the pulses of Q1 switch are in on period (high) the pulses for lower leg switch Q4 are in the off period (low). When Q1 pulses are high we can get the output voltage in the positive half cycle and when the Q4 pulses are high the output voltage will have negative half cycle. Fig 9 shows the simulation results of SPWM technique pulses, the inverter output voltage and the output current waveforms

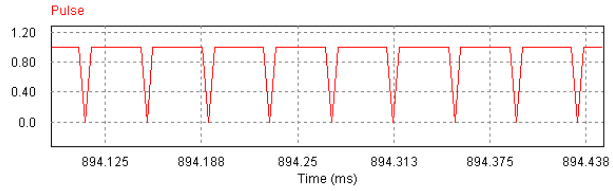
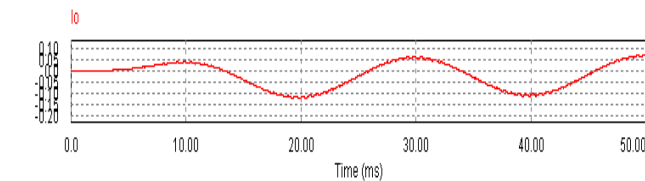
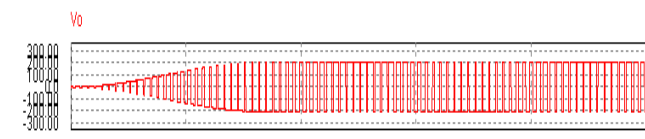
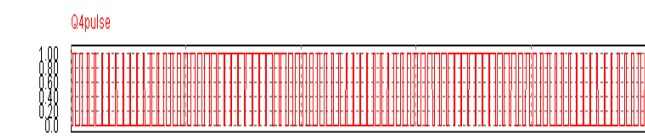
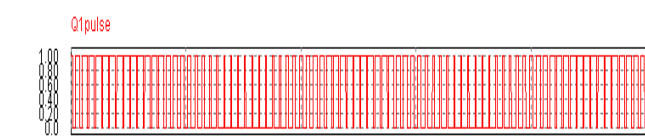
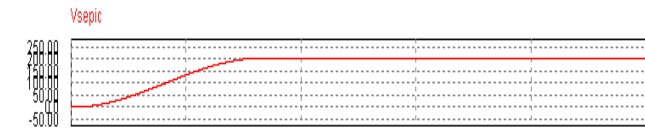
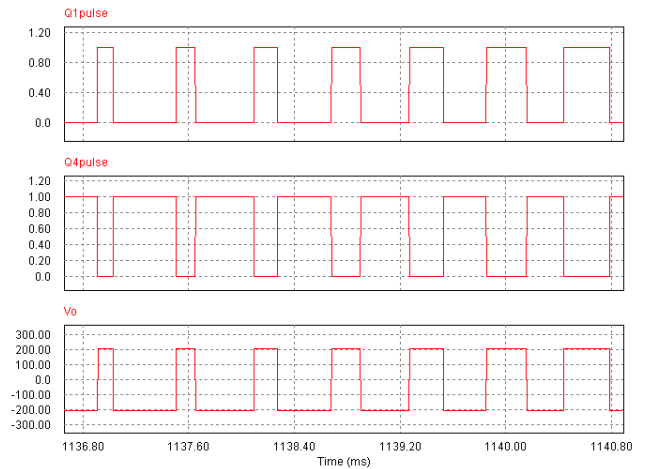



Fig. 8 The SEPIC converter output voltage and the inverted output voltage as a result of SPWM pulses

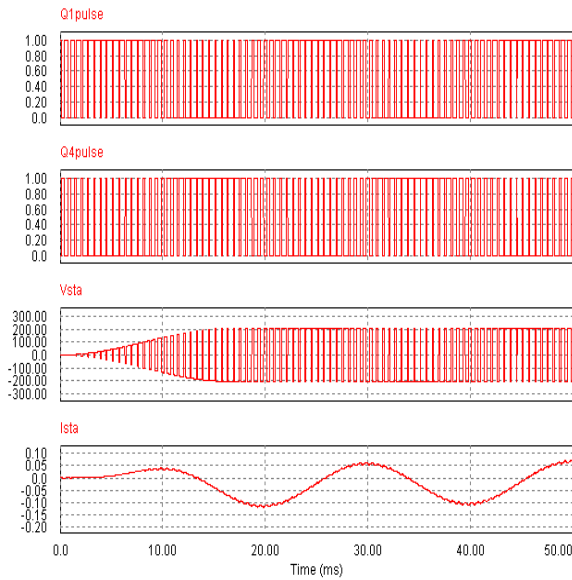

Fig 9. Upper leg switch pulse, lower leg switch pulse, output voltage and current waveforms

B. Hardware Results

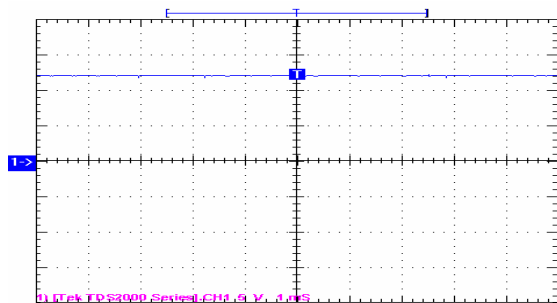

Fig.10 Input voltage waveform

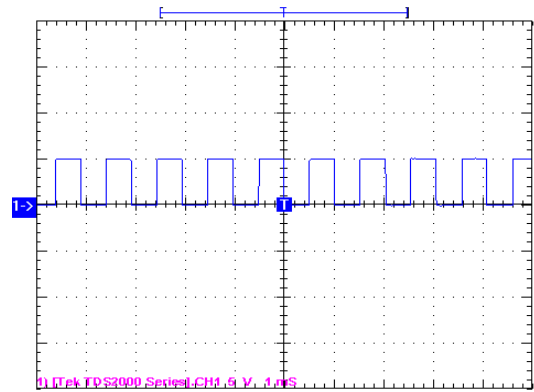

Fig.11 Pulse Output From the Controller Circuit

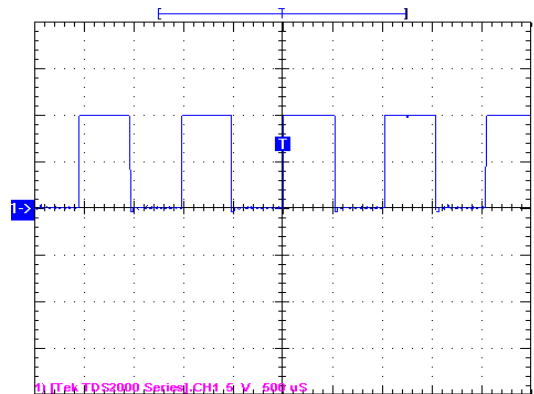

Fig.12 Driver circuit output

The input voltage of the hardware prototype is the 12V DC input of the SEPIC converter. This 12V DC input voltage is measured and shown in fig10. The controller circuit output pulse has the magnitude of 5V. This output is shown in fig11. Fig 12 shows the driver circuit output of 10V. Fig 13 shows the boosted DC voltage of 200V from the SEPIC converter circuit. Finally 180V peak to peak AC square wave, which is the output of inverter circuit, is shown in fig 14. With the implemented hardware prototype a single phase induction motor is running with the speed of 5659rpm. The rated speed of the machine is 6000rpm. The specifications of this single phase induction motor is 230V, 0.35A, 50W, 6000rpm.

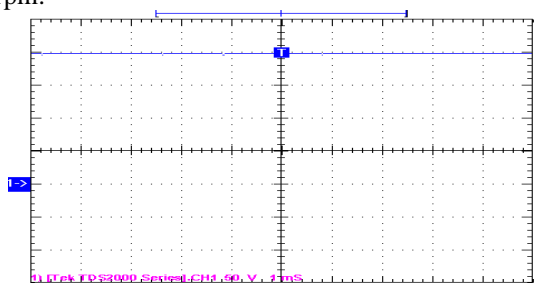

Fig.13 SEPIC converter output waveform

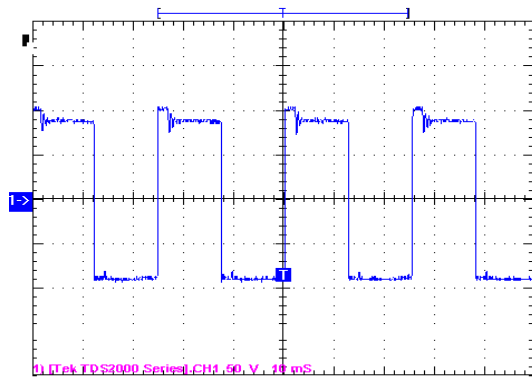

Fig.14 Inverter circuit output waveform

VI. CONCLUSION

This paper presented the simulation work of a Photovoltaic array feeding a three phase induction motor. SEPIC converter and voltage source inverter were used as interface between PV module and the induction motor. P&O MPPT Algorithm was used to obtain the maximum power point operation of PV module. The simulation works of these circuits were carried out in the MATLAB and PSIM software. The output voltage of inverter is increased and the current is reduced with the MPPT algorithm implementation. Experimental work has been done with the SEPIC converter and voltage source inverter to run the single phase induction motor using DC source. A PIC microcontroller was used to generate the pulses for driving the switch of the SEPIC converter. The boosted DC voltage of the SEPIC converter circuit output and inverted AC output waveforms were shown in the results.

VII. APPENDIX

A. Specification of BPSX150S PV Module:

- Maximum Power (Pmax) = 150W
- Voltage at Pmax (Vmp) = 34.5V
- Current at Pmax (Imp) = 4.35A
- Open-Circuit Voltage (Voc) = 43.5V
- Short Circuit Current (Isc) = 4.75A
- Temperature Coefficient of Isc = 0.065±0.015% /°C

B. Key features of PIC 16F877A Microcontroller:

Table 7.1 PIC Microcontroller Key Features

Key Features	PIC16F877A
Operating Frequency	DC - 20 MHz
FLASH Program Memory(14-bit words)	8K
Data Memory (bytes)	368
EEPROM Data Memory	256
Interrupts	15
I/O Ports	Ports A,B,C,D,E
Timers	3
Capture/Compare/PWM Modules	2
10-bit Analog-to-Digital Module	8 input channels
Instruction Set	35 instructions

REFERENCES

- [1] E. E. Jimenez-Toribio, A. A. Labour-Castro and F.M.RoDriguez, “Sensorless Controll of SEPIC and Cuk Converters for DC Motors using Solor Panels” in *proceeding on Electrical Machines and Drives conference, IEMDC-09*, 2009, pp 1503-1510.
- [2] R. B. Darla, “Development of Maximum Power Point Tracker for PV Panels Using SEPIC Converter” in *proceeding on Telecommunications Energy conference, INTELEC 2007*, pp 650 655.
- [3] B. Santhosh Kumar, S. Arul Daniel, and H. Habeebullah Sait, “Analog controller for Photovoltaic array fed inverter driven Single-phase induction motoraq” , in *proceeding on Electrical and Electronics Engineering international conference(ELECO2009)*, pp: I-302-I-305, 2009.
- [4] B.Ismail, S.Taib, A. R Mohd Saad, M. Isa, C. M. Hadzer, “Development of a Single Phase SPWM Microcontroller-Based Inverter”, in *proceedings on IEEE International Conference of Power and Energy, (PECON-06)*, pp 437-440.
- [5] S. M. Mohaiminul Islam, Gazi Mohammad Sharif, “Microcontroller Based Sinusoidal PWM Inverter for Photovoltaic Application”, in *proceedings on first International Conference of Development in Renewable Energy Technology (ICDRET-2009)*, p-1.
- [6] J.G. Llorente,E.I.Ortiz-Rivera, A.S. Llinas, “Analysing the Optimal Matching of DC Motors to Photovoltaic Modules via DC-DC Converters” in *proceedings on Applied Power Electronics conference (APEC)* ,pp-1062-1068
- [7] M.Veerachary and K. S. Shinoy, “ V²- Based Power Tracking for Nonlinear PV Sources” , *IEE proceeding on Electrical Power Applications*, Vol. 152, No. 5, pp 1263-1270, September 2005.
- [8] M.S. Jamri and T.C.Wei, “Modeling and Control of a Photovoltaic Energy System using the State Space Average Technique” in *proceeding on American Journal of Applied Science-7*, 2010, pp 682-691.
- [9] M. G. Villalva, J.R. Gazoli, E. R. Filho, “Comprehensive Approach to Modeling and Simulation of PV Arrays”, *IEEE Transactions on Power Electronics*, Vo. 24, No. 5, pp 1198-1208, May 2009.
- [10] Datasheet of “Design a SEPIC Converter” by National Semiconductor, May-2006
- [11] Datasheet of “PIC16F87X “ by microchip technology, 2001.
- [12] “Transformer and inductor Design Handbook”, by Colonel Wm. T. Melyman, Third Edition, 2004
- [13] B. Wittig, W.T.Franke, F.W.Fuchs, “Design and Analysis of a DC/DC/AC Three Phase Solar Converters with Minimized DC Link Capacitance”, in

proceedings on 12th European conference on Power Electronics and Applications, Aalborg, 2007

- [14] Zhou Hai-feng, Xu Zhi-long , Lin Zhong-hua, Wang Rong-jie, “Simulation Design of Inverter in Solar Photovoltaic System Based on MCU”, *in proceedings on Photonics and optoelectronics conference(SOPO-2009)*,p-1.
- [15] Laurenfiu Rimifriu, Mihai Lucanu, Cristian Aghion, Ovidiu Ursaru, “Control With Microcontroller For Pwm Single-Phase Inverter”, *in proceedings on international conference of Signals,Circuits and System(SCS-2003)*,pp:265-268.
- [16] Power Electronics Circuits, Devices and Applications, by M.H. Rashid, 3rd Edition, Pearson Education-2004



1 Sivaraman.P received the BE degree in electrical and electronics engineering from Bharathiar University, Coimbatore , in 2002 and the M.Tech. Degree from the School of Electrical and Electronics Engineering SASTRA University, Thanjavur, Tamilnadu, in 2004. Now he is pursuing PhD in Anna University of Technology Coimbatore. From 2004 onwards he is working with the Bannari Amman Institute of Technology, Sathyamangalam,Erode,Tamilnadu, where his current research interest include power converter for photovoltaic application and distributed power generation . He has published many papers in national and international journals and conferences to his credit.



2. Dr.A.Nirmalkumar completed his graduation and post graduation in Electrical Engg from Calicut and Kerala University in 1972 &1976 respectively. Completed his Doctorate from Bharathiar University in 1992. His area of specialization includes Power converters for renewable energy application and drives. He has more than 30 years of teaching experience. He is guiding at present 20 research scholars. He is the recipient of Institution of Engineers Gold Medal for the year 1989. He has many publications in national and international journals to his credit